

UNMENTIONED TOLERANCES

LINEAR DIMENSIONS (SUPTO MACHINED) TOL.	0	6	315	1000
ABOVE	0	6	315	1000
ANGLES	± 1/2°			

ALL INFORMATION CONTAINED IN THIS DOCUMENT IS CONFIDENTIAL AND THE PROPERTY OF KIRLOSKAR ELECTRIC CO.LTD. REPRODUCING OF THESE IN ANY FORM IS TO BE DONE WITH THE SPECIFIC PERMISSION OF THE COMPANY.

**DIMENSIONAL DRAWING**

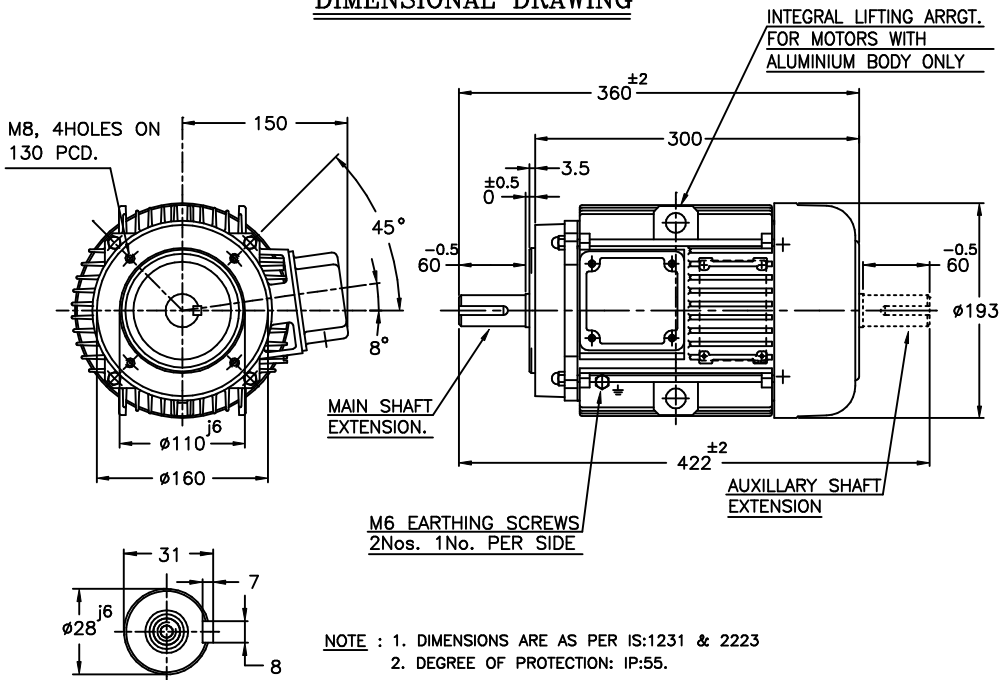

**DETAILS OF MAIN & AUXILIARY SHAFT EXTENSION**

- NOTE :
1. DIMENSIONS ARE AS PER IS:1231 & 2223
  2. DEGREE OF PROTECTION: IP:55.
  3. PROTECTED CENTRE HOLE AT SHAFT EXTENSION AS PER IS:2540. "M10 X 24" FOR 'D'- ø28
  4. TERMINAL BOX CAN BE ROTATABLE THROUGH 360° IN STEPS OF 90°.
  5. KEY & KEYWAY ARE AS PER IS:2048 & TOLERANCE ON KEYWAY IS P9.

SURFACE ROUGHNESS (MAX) AS PER KSD-02-027

RM	50	12.5	25	1.6	3.2	6.3	0.2	0.4	0.8	0.025	0.05	0.1
OLD	✓	✓	✓	✓	✓	✓	✓	✓	✓	✓	✓	✓
NEW	✓	✓	✓	✓	✓	✓	✓	✓	✓	✓	✓	✓

UC: CHAM: UNMENTIONED

REV.	ZONE	DCN.No.	BRIEF RECORD	SIGNATURE	DATE	PRINTS ISSUED TO
1	-	0122209	REDRAWN IN A NEW FORMAT.	Sd/-	10/01/09	QA PRODUCTION MKTG
8	7	6	5			

**Z122611100JR**

THIS SUPERSEDES ..... FROM dt ..... AS PER DCN No.....

THIS SUPERSEDED BY ..... FROM dt ..... AS PER DCN No.....

MATERIAL SPECIFICATION	RAW MATERIAL SIZE	WEIGHT kg	SCALE	
-	-	RM FIN.		NTS
CASTING/FAB REF.		No.P.S.:-	REDRAWN	
USED ON		sd/-	CHECKED	STANDARD
CPM100L		dt10/01/09	sd/-	APPROVED
TITLE:		dt10/01/09	sd/-	sd/-
DIMENSION SHEET		dt10/01/09	dt10/01/09	dt10/01/09
KIRLOSKAR ELECTRIC COMPANY LTD. HUBLI-580030 (INDIA)		SHEET ONE OF ONE		

**32261198R1**

FORM No. 02 201 028 (ISSUE 7)