

UNMENTIONED TOLERANCES

LINEAR DIMENSIONS (SUPTO MACHINED) / (D.L. (MACHINED)) / (D.L. (MACHINED))	0	6	315	1000
ABOVE	0	6	315	1000
ANGLES	± 1/2°			

ALL INFORMATION CONTAINED IN THIS DOCUMENT IS CONFIDENTIAL AND THE PROPERTY OF KIRLOSKAR ELECTRIC CO.LTD. REPRODUCING OF THESE IN ANY FORM IS TO BE DONE WITH THE SPECIFIC PERMISSION OF THE COMPANY.

SURFACE ROUGHNESS (MAX) AS PER KSD-02-027

RM	50	12.5	25	1.6	3.2	6.3	0.2	0.4	0.8	0.025	0.05	0.1
OLD	✓	✓	✓	✓	✓	✓	✓	✓	✓	✓	✓	✓
NEW	✓	✓	✓	✓	✓	✓	✓	✓	✓	✓	✓	✓

UC: UNMENTIONED CHAM: R0.5

DIMENSIONAL DRAWING

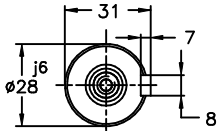
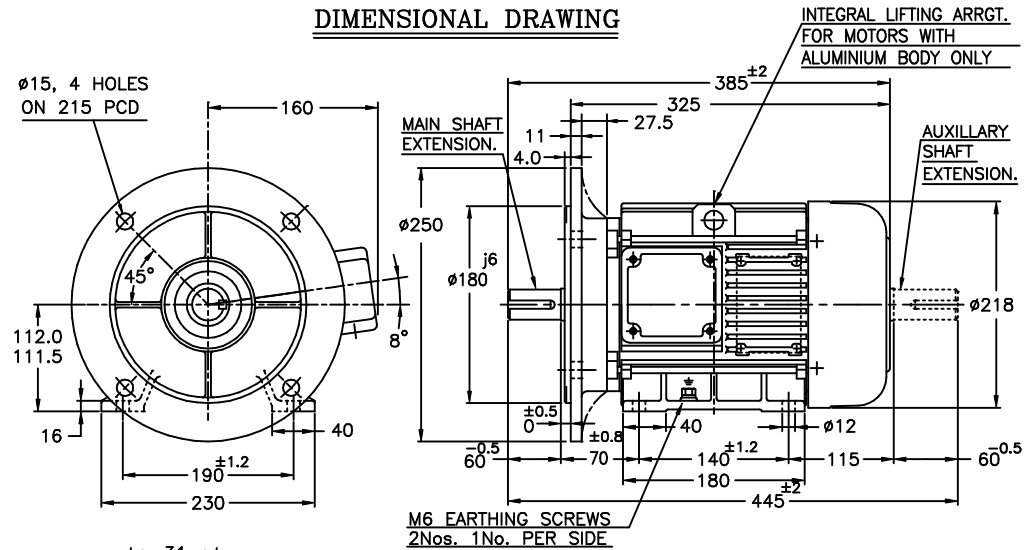

DETAILS OF MAIN & AUXILIARY SHAFT EXTENSION

- NOTE :**
1. DIMENSIONS ARE AS PER IS:1231 & 2223
 2. DEGREE OF PROTECTION: IP:55.
 3. PROTECTED CENTRE HOLE AT SHAFT EXTENSION AS PER IS:2540. "M10 X 24" FOR "D" - Ø28
 4. TERMINAL BOX CAN BE ROTATABLE THROUGH 360° IN STEPS OF 90°.
 5. KEY & KEYWAY ARE AS PER IS:2048 & TOLERANCE ON KEYWAY IS P9.

TERMINAL BOX ARRANGEMENT

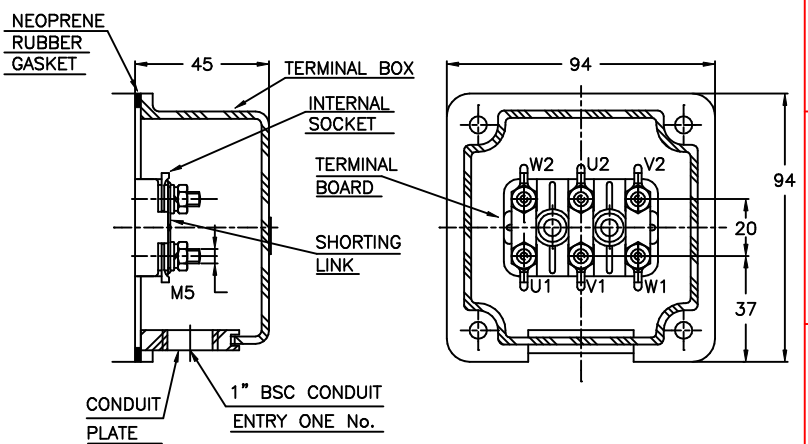

NOTE: MAX. CABLE SIZE : MAIN-1x3Cx16 sqmm.

Z122617100JR

REV.	1	ZONE	-	DCN.No.	0122209	BRIEF RECORD	7	6	5	
DESCRIPTION	REDRAWN IN A NEW FORMAT.						Sd/-	10/01/09	OA	PRODUCTION
PRINTS ISSUED TO							SIGNATURE	DATE	PRINTS ISSUED TO	MKTG

THIS SUPERSEDES FROM dt AS PER DCN No.....		THIS SUPERSEDED BY FROM dt AS PER DCN No.....	
MATERIAL SPECIFICATION	RAW MATERIAL SIZE	WEIGHT kg	SCALE
-	-	RM FIN.	NTS
CASTING/FAB REF.	RAW MATERIAL SIZE	No.P.S.:-	SCALE
USED ON	RAW MATERIAL SIZE	REDRAWN	CHECKED
FBPM112M	RAW MATERIAL SIZE	sd/-	sd/-
TITLE:	RAW MATERIAL SIZE	dt10/01/09	dt10/01/09
DIMENSION SHEET	RAW MATERIAL SIZE	dt10/01/09	dt10/01/09
KIRLOSKAR ELECTRIC COMPANY LTD. HUBLI-580030 (INDIA)		SHEET ONE OF ONE	



FORM No. 02 201 02B (ISSUE 7)