

**INSTRUCTIONS ON  
INSTALLATION  
OPERATION AND  
MAINTENANCE FOR  
KIRLOSKAR PUMP  
TYPE MF**

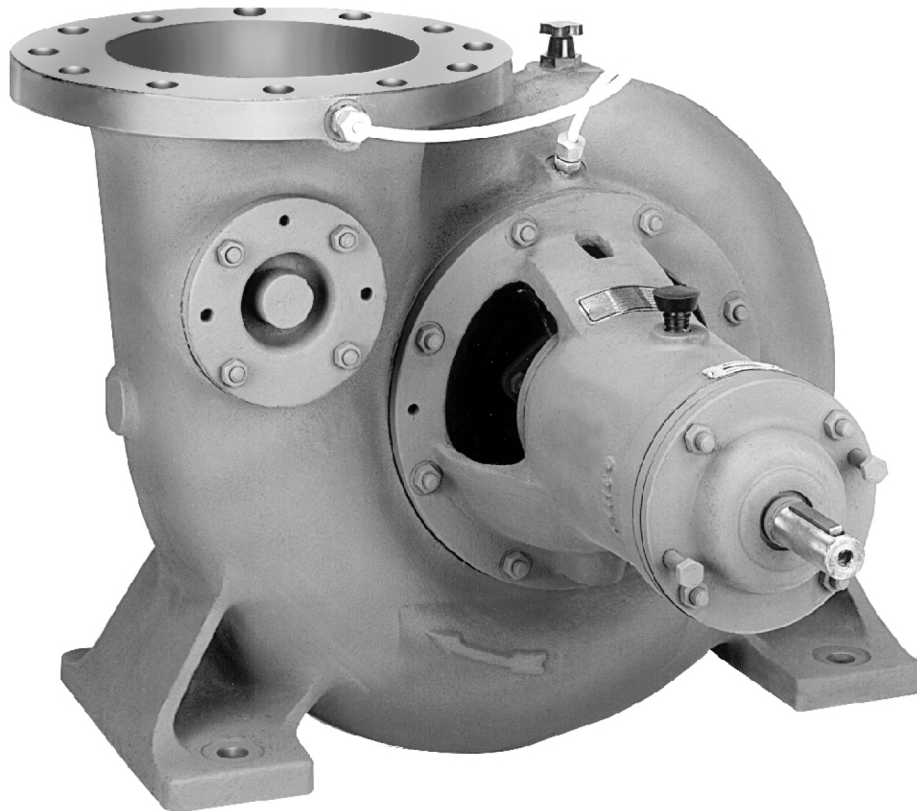

Enriching Lives



## **KIRLOSKAR BROTHERS LIMITED**

Udyog Bhavan, Tilak Road, Pune 411 002 (India)

### **WARRANTY**

We warrant that the pump supplied by us is free from defective material and faulty workmanship. This warranty holds good for a period of 12 months from the date of commissioning of the equipment or 18 months from the date of despatch from our factory, whichever is earlier. Our liability in respect of any complaint is limited to replacing part/parts free of charge ex-works or repairs of the defective part/parts only to the extent that such replacement / repairs are attributable to or arise solely from faulty workmanship or defective material.

The warranty holds good only for the products manufactured by us.

**KIRLOSKAR BROTHERS LIMITED**

## TABLE OF CONTENTS

---

Sr. No.	Page No.
<b>FOR MF, MFX, MF-E, MF-M</b>	
1. GENERAL . . . . .	1
2. INSTALLATION . . . . .	1
3. OPERATION . . . . .	1
4. TECHNICAL DATA . . . . .	2
5. MAINTENANCE . . . . .	6
6. OVERHAULING . . . . .	6
7. LIST OF COMPONENTS, RECOMMENDED STOCK OF SPARE PARTS & DRAWINGS . . . . .	10
<b>FOR MF 200</b>	
8. GENERAL . . . . .	15
9. INSTALLATION . . . . .	15
10. OPERATION . . . . .	15
11. TECHNICAL DATA . . . . .	16
12. MAINTENANCE . . . . .	17
13. OVERHAULING . . . . .	18
14. LIST OF COMPONENTS, RECOMMENDED STOCK OF SPARE PARTS . . . . .	20

---

PLEASE FURNISH COMPLETE NAME PLATE DETAILS NAME AND PART NOS.,  
MATERIAL OF CONSTRUCTION & QUANTITY WHILE ORDERING SPARE PARTS.

## 1. GENERAL

1.1 This booklet covers instructions for following type of MF Pumps :  
MF 171/2 - 20

MF 20-25	MFx 20-25	MF 35-35	MF x 35-35
MF 250		MF 35-40	MF x 40-40
MF 25-25	MFx 25-25	MF 40-40	
MF 25-30	MFx 25-30	MF 40-45	
MF 300	MFx 25-30 E	MF 50-50	
MF 30-35	MFx 30-35 M	MF 55-60	
	MFx 40-40 E	MF 60-65	
	MFx 55-60 E		

1.2 These are single stage, horizontal spindle volute type foot mounted end suction pumps fitted with oil lubricated ball bearings and thrust bearing. MF-E & MFX pumps are provided with enclosed type mixed flow impeller. MF Pumps are provided with semi open type mixed flow impeller. The delivery casing can be offered in following three different execution.

- 1) MEGHA - (Standard) Pointing Vertical upwards.
- 2) MRUGA - Pointing horizontal
- 3) TRISHA - Pointing at 45<sup>o</sup> downwards to the horizontal.

1.3 Pumps when properly installed and given due care in operation and maintenance should operate satisfactorily for a long period.

1.4 When the pump is received some time before the actual use of pump, it should be inspected and located in dry place. The coupling should be rotated once in a month to prevent pitting of bearing surfaces.

1.5 The special problems arising at site should be referred to the supplier. Full name plate details should be furnished while exchanging correspondence in connection with these pumps.

## 2. INSTALLATION :

2.1 For location, preparing foundation, installation, alingment, general maintenance, trouble shooting etc. the instructions given in our publication 'General Instruction Manual on Centrifugal pumps' which is printed alongwith this manual must be followed carefully.

2.2 The external sealing connection to the pump if applicable, must be made after installing and before commissioning of pump.

## 3. OPERATION

3.1 Before starting the pump check the following :

3.1.1 The pump rotates freely.

3.1.2 Sealing connection, if any, is properly tightened and adjusted.

3.1.3 Oil level in the bearing housing.

3.1.4 The direction of rotation of motor corresponds to the direction of rotation of the pump.

3.1.5 The pump and section pipe is fully primed with the liquid.

3.1.6 Stuffing box is packed properly and gland is tightened.

3.1.7 Valve on delivery side is closed

3.1.8 The cock for pressure gauge connection is closed.

### **3.2 Starting the pump :**

3.2.1 Open delivery valve 30% approx of full open.

3.2.2 Start the motor. Let the prime mover pick up its full speed.

3.2.3 Open the valve on delivery side fully.

3.2.4 Open the cock for pressure gauge connection.

### **3.3 During running of pump, check the following and regulate if necessary :**

3.3.1 The pump and motor is running smooth.

3.3.2 The flow of sealing liquid is uninterrupted if external sealing is applicable.

3.3.3 Leakage through stuffing box is normal. There should be leakage of 60 to 80 drops per minute.

3.3.4 The bearing not getting heated up excessively.

3.3.5 Head and capacity developed by the pump is as specified.

3.3.6 Power consumption is within limit.

3.3.7 Ensure that there is no mechanical friction in the pump.

3.3.8 Stop the pump immediately if any defects are noticed. DO NOT START IT AGAIN UNLESS DEFECTS ARE RECTIFIED. REPORT IMMEDIATELY TO THE SUPPLIER IF IT IS NOT POSSIBLE TO RECTIFY THE DEFECTS.

### **3.4 Stopping the pump :**

3.4.1 Close the valve on delivery side.

3.4.2 Stop the motor.

3.4.3 Close the sealing connection.

3.4.4 If the pump is not required to be operated for long time drain the casing completely. Also drain the lubrication oil completely. The bearing housing should be dried internally with hot air and should be flushed with moisture free protective such as light oil or kerosene.

## **4. TECHNICAL DATA :**

4.1 Direction of rotation :

The standard direction of rotation is clockwise when viewed from driving end. The pump with reverse direction of rotation is not possible.

### **4.2 Bearings :**

The pumps are fitted with antifriction heavy duty single row deep groove ball bearings at driving and non driving end. Also a thrust bearing is provided at DE to take residual axial thrust. The details of bearings are given in Technical Data I. the designation of bearings are as per SKF catalogue. However, equivalent bearings in type, capacity and dimensions also can be used.

**4.3 Lubrication :**

Bearings are oil lubricated. The oil used should be a highly refined straight mineral product of high emulsibility free from running and acid forming tendencies. Detergent oil may cause foaming and emulsion of difficulties and should not be used. The oil should conform to following grades of oil available in the market.

Manufacturers	Trade Name
INDIAN OIL	SERVOSYSTEM - 57
HINDUSTAN PETROLEUM	ENCLO - 53

**4.4 Refilling period :**

For a new pump oil is to be changed after 200 hours of working. For subsequent filling, the oil is to be changed after about 1000 hours of working.

**4.5 Bearing temperature :**

The maximum allowable bearing temperature is 80°C.

**4.6 Stuffing box :**

The stuffing boxes are extra deep to reduce leakage and minimise the maintenance. Split lantern ring is provided for sealing purpose.

**4.7 Sealing**

For MF Pumps self liquid only is used for sealing in most of the cases. However sealing arrangement with external liquid can be supplied against specific request. The various type of sealing arrangements are shown below. For MFX and MF-E Pumps sealing is grease Sealing in most of the cases.

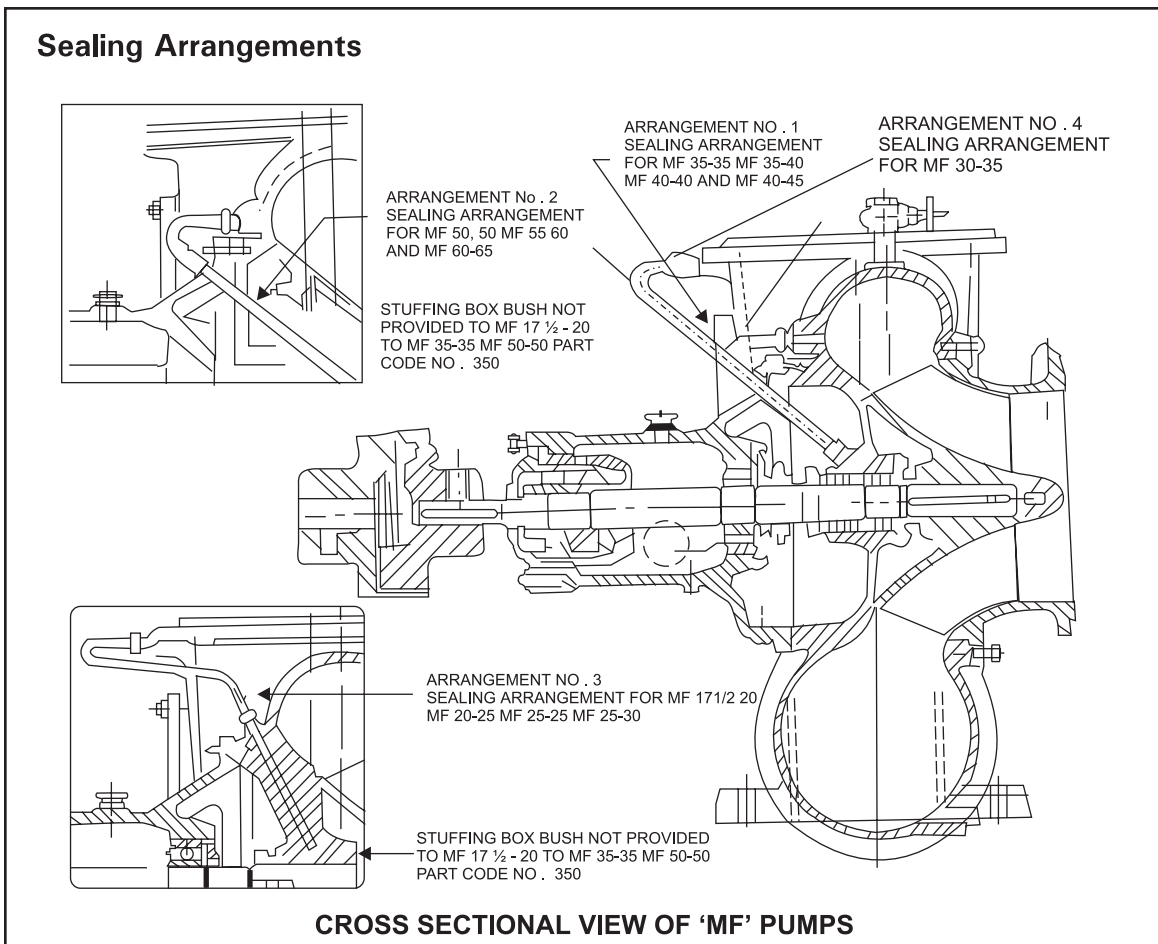

4.7.1 Pressure & Quantity of Water required for stuffing box sealing when supplied from external source :

The water should be at pressure of one atmosphere above the pressure developed by the pump. Water quantity : 5 liters/minute.

4.8 Stuffing box packing :

Champion style '3116' Graphited cotton is used in the standard supply for MF pumps champion style '1100' Graphited Asbestos is used in the standard supply for MFX & MFE Pumps. However packing suitable for liquid handled is also supplied against order.

4.9 Flexible coupling :

The pumps are supplied with Love-Joy type couplings. For the sizes, please refer to Technical Data II.

4.10 Interchangeability chart of components :

Part No.	Description Part	PUMP MODELS												
		MF 171/2-20	MFX 20-25 MF 250 MF 20-25	MFX 25-25 MF 25-25	MFX25-30/ MF 25-30 MF 25-30E MF 300	MF 30-35	MF 35-35 MFX 35-35	MF 35-40	MF 40-40E MFX 40-40 MF 40-40	MF 40-45	MF 50-50	MF 55-60 MF 55-60E	MF 60-65	MF 30-35 M
156/154*	Impeller	1	2	3	4	5	6	6	7	7	8	9	10	11
180	Shaft	1	1	2	2	3	3	3	4	4	5	5	6	3
240	Bearing Housing	1	1	2	2	3	3	3	4	4	5	5	6	3
241	Cartridge	1	1	2	2	3	3	3	4	4	5	5	6	3
260.1/	Ball Bearing													
260.2	DE & NDE	1	1	2	2	3	3	3	4	4	5	5	6	3
262	Thrust Bearing	1	1	2	2	3	3	3	4	4	5	5	6	3
270/271	Bearing Cover DE & NDE	1	1	2	2	3	3	3	4	4	5	5	6	3
500.1	Oil Seal													
500.2	DE & NDE	1	1	2	2	3	3	3	4	4	5	5	6	3
311	Shaft sleeve under stuffing box	1	1	2	2	3	3	3	4	4	5	5	6	3
223	Gland	1	1	2	2	3	3	3	4	4	5	5	6	3
227	Split lantern ring	1	1	2	2	3	3	3	4	4	5	5	6	3
199	Shoulder ring	1	1	2	2	3	3	3	4	4	5	5	6	3
390 & 391	Love joy Coupling	1	2	3	3	3	4	4	5	5	6	7	7	8
190	Casing ring (only for MFX & MFE pump)	-	-	-	1 ▲	-	2	-	3	-	-	4	-	-
272	Thrust Bearing Adaptor	1	1	2	2	3	3	3	4	4	5	5	6	3
320.1	Impeller Key	1	1	2	2	3	3	3	4	4	5	5	6	3
320.2	Impeller & Shaft Sleeve key	1	1	2	2	3	3	3	4	4	5	5	6	3

\* For MFX & MFE PUMPS

▲ For MFE Pumps. Impeller is common in case of MFX 25-25 and MFX 25-30 Pump.

#### 4.10 Interchangeability chart of components (Continued) :

Part No.	Description Part	PUMP MODELS												
		MF 171/2 -20	MFX 20-25 MF 250 MF 20-25	MFX 25-25 MF 25-25	MFX25-30/ MF 25-30 MF 25-30E MF 300	MF 30-35	MF 35-35 MFX 35-35	MF 35-40	MF 40-40E MFX 40-40 MF 40-40	MF 40-45	MF 50-50	MF 55-60 MF 55-60E	MF 60-65	MF 30-35 M
321	Coupling Key	1	1	2	2	3	3	3	4	4	5	5	6	3
330	Impeller Nut	1	1	2	2	3	3	3	4	4	5	5	6	3
335	Bearing Nut	1	1	2	2	3	3	3	4	4	5	5	6	3
336	Lock Nut	1	1	2	2	3	3	3	4	4	5	5	6	3
444	Oil feeding plug	1	1	1	1	1	1	1	1	1	1	1	1	1
605	Oil Drain Plug	1	1	1	1	1	1	1	2	2	2	2	2	1
604	Plug for st. box drain	1	1	1	1	1	1	1	2	2	2	2	2	1
430	Gland packing	1	1	2	2	3	3	3	4	4	5	5	6	3
522.2	'O' ring for suction cover & pump casing	1	2	3	3	4	5	5	6	6	7	8	9	10
410	Lockwasher for Impeller	1	1	2	2	3	3	3	4	4	5	5	6	7
446	Oil level indicator	1	1	1	1	1	1	1	1	1	1	1	1	1

Note : Same numbers in the same horizontal line represent interchangeable component.

#### 4.11 TECHNICAL DATA-1 :

PUMP MODEL	Flange size in mm		Ball bearing		Thrust bearing DE	Approx. qty of oil in brg. hsg. in litres	Sizes of all seals OD x ID x THICK	
	Del.	Suc.	DE	NDE			DE	NDE
MF 171/2 -20	200	175	6408	6408	51310	0.8	50X35X10	62X40X10
MFX 20-25 } MF 20-25 }	250	200	6408	6408	51310	0.8	50X35X10	62X40X10
MF 250	250	250	6408	6408	51310	0.8	50X35X10	62X40X10
MF 25-25	250	250	6410	6410	51312	1.5	65X45X12	78X50X13
MFX 25-25	250	250	6410	6410	51312	1.5	65X45X12	78X50X13
MF 25-30	300	250	6410	6410	51312	1.5	65X45X12	78X50X13
MFX 25-30	300	250	6410	6410	51312	1.5	65X45X12	78X50X13
MF 25-30E	300	250	6410	6410	51312	1.5	65X45X12	78X50X13
MF 300	300	300	6410	6410	51312	1.5	65X45X12	78X50X13
MF 30-35	350	300	6412	6412	51314	2.3	80X55X13	85X60X13
MF 30-35 M	350	350	6412	6412	51314	2.3	80X55X19	85X60X13
MF 35-35	350	350	6412	6412	51314	2.3	80X55X13	85X60X13
MFX 35-35	350	350	6412	6412	51314	2.3	80X55X13	85X60X13
MF 35-40	400	350	6412	6412	51314	2.3	80X55X13	85X60X13
MF 40-40 } MF 40-40 E }	400	400	6415	6415	51320	3.6	105X72X13	105X75X13
MFX 40-40	400	400	6415	6415	51320	3.6	105X72X13	105X75X13
MF 40-45	450	400	6412	6415	51320	3.6	105X72X13	105X75X13
MF 50-50	500	500	6418	6418	51322	6.5	110X85X13	120X90X13
MF 55-60	600	550	6418	6418	51322	6.5	110X85X13	120X90X13
MF 55-60E	600	550	6418	6418	51322	6.5	110X85X13	120X90X13
MF 60-65	650	600	6324	6324	51328	9.5	130X105X13	150X10X15



#### 4.12 TECHNICAL DATA-II :

PUMP MODEL	Stuffing box packing			'O' ring specification size in mm			Love Joy Coupling Type	'O' Ring 522.3 MFX MF-E	'O' Ring 522.4 MFX
	Size sq. mm	Length mm	Position of lantern ring from impeller	Part No. 522.1 ID x Thick	Part No. 522.2 ID x Thick	Part No. 522.3 ID x Thick			
MF 171/2 -20	8	915	2+L+4	29x3	235x3	—	SW150	—	—
-MF 20-25	8	915	2+L+4	29x3	273x3	—	SW190	—	—
MF X 20-25	8	915	2+L+4	29x3	273x3	—	SW190	—	—
MF 250	8	915	2+L+4	29x3	273x3	—	SW190	—	—
MF 25-25	12	1040	2+L+3	36x5	332x4	—	C276	—	—
MFX 25-25	12	1040	2+L+3	36x5	332x4	—	C276	56x4	222x4
MFX 25-30	12	1040	2+L+3	36x5	332x4	—	C276	56x4	222x4
MF 25-30	12	1040	2+L+3	36x3	332x4	—	C276	—	—
MF 30-35	12	1188	2+L+3	48x3	402x4	—	C276	—	—
MF 30-35M	12	1188	2+L+3	48x3	402x4	—	C295	—	—
MF 35-35	12	1188	2+L+3	48x3	472x4	—	C295	—	—
MFX 35-35	12	1188	2+L+3	48x3	472x4	—	C295	94x4	332x4
MF 35-40	12	1188	2+L+3	48x3	472x4	—	C295	—	—
MF 40-40	16	1890	2+L+4	67x3	540x6	—	C2955	—	—
MFX 40-40 } MF 40-40E }	16	1890	2+L+4	67x3	540x6	—	C2955	116x4	372x4
MF 40-45	16	1890	2+L+4	67x3	540x6	—	C2955	—	—
MF 50-50	19	2265	2+L+4	80x3	673x6	—	C300	—	—
MF 55-60	19	2265	2+L+4	80x3	746x8	432x6	H3567	—	—
MF 55-60E	19	2265	2+L+4	80x3	746x8	432x6	H3567	492x4	—
MF 60-65	19	2450	2+L+4	85x5	806x8	500x8	H3567	—	—
MF 25-30E	12	1040	2+L+3	36x3	332x4	56x4	C276	222x4T	—

#### 5. MAINTENANCE :

Preventive maintenance schedule is the periodical checks and precautions by which possibilities of failure and break down are made very remote.

##### 5.1 Daily checks :

- 5.1.1 Pressure gauge readings
- 5.1.2 Bearing temperature
- 5.1.3 Oil level in bearing housing
- 5.1.4 Leakage through st. box
- 5.1.5 Noise and vibrations
- 5.1.6 Voltage and current.

##### 5.2 Periodical checks :

- 5.2.1 Check the alignment of pumpset
- 5.2.2 Calibrate the measuring instruments
- 5.2.3 Check the sealing connections.

#### 6. OVERHAULING :

With normal daily operating spell, the pump will be due for overhaul after about 5000 working hours. This work should be done by skilled personnel. Please refer to the cross sectional drawing while dismantling and reassembling the pump.

## 6.1 Dismantling

Drain the delivery casing completely by removing drain plug (601).

- 6.1.1 Disconnected the pump from suction and delivery piping and auxiliary piping if any. Remove coupling grub screws (653. 1 & 653.2) Unscrew the bolts holding the pump on base plate and take out the pump.
- 6.1.2 Drain oil from bearing housing (240) by unscrewing the drain plug (605).
- 6.1.3 Remove, oil level indicator (446) and accessories such as vent valve (MF 17 1/2-20, to MF 25-30 MFX 20-25, 25-25, 25 -30, MF 25-30E) Pipe and Wheel Cock (MF 30-35 to MF 60-65, MF30-35M, MFX - 35-35, 40-40, MF 40-40E, MF 55-60E from pump casing (101). Remove pump coupling (390). Take out coupling key (321).
- 6.1.4 Remove the nuts holding down suction cover (210) from delivery casing (101). Take out suction cover along with (in case of MFX and MFE pumps) casing ring (190) by tightening release bolts. Take 'O' rings (522.2) from suction cover (210).
- 6.1.5 Unscrew impeller nut (330). Take out the lock washer for impeller nut (410).
- 6.1.6 Remove the impeller (156 for MF & 154 only for MFX & MFE Pump ) from pump shaft.
- 6.1.7 Take out impeller key (320.1)
- 6.1.8 Remove nuts holding down bearing housing (240) to the delivery casing (101) and take it out carefully.
- 6.1.9 Unscrew gland nuts and remove gland (223). Take out gland packing (430) and lantern ring (227)
- 6.1.10 For pumps type MF 55-60, MF 55-60E and MF 60-65 unscrew the nuts holding casing cover (220) and delivery casing. Take out casing cover by tightening release bolts. Also remove 'O' ring. (522.1)
- 6.1.11 Remove stuffing box bush (350) from delivery casing by removing hexagonal bolts. The stuffing box bush is not provided in pumps type MF 17 1/2 -20 to MF 35-35 and MF 50-50 & MFX 35-35.
- 6.1.12 Remove shaft sleeve (311) 'O' ring (522.1) and key for impeller and shaft sleeve (320.2). Take out liquid deflector (236).
- 6.1.13 Remove bearing cover DE (270) alongwith oil seal (500.1) removing bolts and by tightening release bolts. Also remove bearing cover from non-driving side (271) alongwith oil seal (500.2) by unscrewing bolts.
- 6.1.14 Take out shaft (180) from bearing housing alongwith bearing lock nut (336), bearing nut (335), ball bearing DE (260.1), thrust bearing (262), cartridge (241) and ball bearing NDE (260.2).
- 6.1.15 Unscrew lock nut (336) and bearing nut (335).
- 6.1.16 Remove whole assembly that is cartridge, ball bearing D.E., thrust bearing by using suitable puller on cartridge (241).
- 6.1.17 Remove ball bearing NDE (260) and take out shoulder ring(199).
- 6.1.18 Remove back vane plate (168) from impeller (154) only for MFX & MFE Pumps.)

This completes the dismantling of the pump.

Before proceeding with reassembly of rotating unit and pump check the following :

- A) Ball bearings are rotating freely and smoothly. Renew them if they are not rotating freely or if the races are deteriorated.
- B) Check the shaft for possible run out. Remove the same before reassembly.
- C) Remove any dust or rust from parts and if necessary apply new paint/coating on the same.
- D) Clean all the parts thoroughly with kerosene or petrol.
- E) If reassembly is not to be made immediately, apply rust preventive, coating on all machined surfaces.
- F) Examine all the parts for refitting worn out etc. Damaged or corroded parts should be replaced by new.
- G) Ensure that newly fitted parts are free from damage and from burrs.
- H) Examine deflector 'O' rings for damage or deterioration. If replaced with new make sure that they are of requisite dimensions.
- I) Check clearance between impeller and suc cover as per following chart. The clearance should be within max. and min. limit. (In case of MF pumps)

Pump Type	Clearance in mm	
	Max.	Min.
1. MF 171/2 -20 to MF 40-45	0.65	0.4
2. MF 50-50 to MF 60-65	0.93	0.65

- J) Check clearance between casing ring and impeller as per following chart (In case of MFX & MFE pump). The clearance should be within max and mini limit.

Sr. No.	Pump Type	Diametrical Clearance between casing Ring & Impeller in mm			
		CI/Br		St. St.	
		Max.	Mini	Max.	Mini
1.	MFX 20-25	0.581	0.42	0.831	0.67
2.	MFX 25-25 } MFX 25-30 }	0.622	0.44	0.872	0.69
		Suc./Del. Side	Suc./Del. Side	Suc./Del. Side	Suc./Del. Side
3.	MFX 35-35	0.783/0.83	0.586/0.612	1.039/1.08	0.836/0.862
4.	MFX 40-40 MF 40-40E	0.824/0.83	0.606/0.612	1.074/1.08	0.856/0.862
5.	MF 25-30E	0.622	0.44	0.372	0.69
6.	MF 55-60 E	0.86/0.94	0.51/0.54	1.11/1.19	0.76/0.79

## 6.2 Reassembly

- 6.2.1 Wipe light clean oil cover shaft (180)
- 6.2.2 Insert shoulder ring (199) from NDE side and fit ball bearing NDE (260)
- 6.2.3. Put compression springs from thrust bearing (483) in the holes provided into cartridge (241). Fit the cage of thrust bearing (262) into cartridge. Fir another cage of thrust bearing on thrust bearing adaptor (272). Also fit bearing adaptor (272) on the shaft.

- 6.2.4 Fit ball bearing (260) at D.E. and N.D.E. Ensure that shoulder ring (199) is fitted at NDE prior to ball bearing. Fit bearing nut (335) and lock it by means of bearing lock nut (336). Fit gasket (514.2) on cartridge (241).
- 6.2.5 Lift the shaft (180) duly fitted with bearings and insert it in bearing housing (240).
- 6.2.6 Fit bearing cover DE (270) and bearing cover NDE (271). Ensure that gasket (514.1) and (514.3) is duly fitted and shaft is rotating freely.
- 6.2.7 Fit stuffing box bush (350) to delivery casing (101). This is only applicable for (pumps type MF 35-40, MF 40-40, MF 40-45, MF 55-60, MFX 40-40 MF40-40E. MF55-60E)
- 6.2.8 Fit stuffing box bush (350) to stuffing box cover (220). Also fit stuffing box cover (220) to delivery casing (101). Ensure that 'O' ring (522.1) is fitted properly. This provision is provided only for pumps type MF 55-60, MF 55-60E and MF 60-65.
- 6.2.9 Insert water deflector (236) and gland (223).
- 6.2.10 Fit bearing housing (240) to delivery casing (101) and tighten the nuts.
- 6.2.11 Fit shaft sleeve (311) alongwith 'O' ring (522.1) and insert key for impeller & shaft sleeve (320.2). Ensure that 'O' ring (522.1) is fitted properly. Fit gasket (515). Fit back vane plate (168) on impeller (154). (In case of MFX 25-25 to MFX 40-40, MF 40-40E, MF 25-30E & MF 55-60E)
- 6.2.12 Fit impeller key (320.1) and fit the impeller (156 & 154)
- 6.2.13 Insert lock washer for impeller nut (410) over pump shaft (180) and tighten impeller nut (330). Lock the impeller nut by means of lock washer (410) Fit casing ring (190) in suc. cover (210). (In case of MFX 35-35, MFX 40-40, MF 40-40E, MF 25-30E & MF 55-60E)
- 6.2.14 Ensure that impeller rotates freely, Fit suction cover (210) duly fitted with 'O' ring (522.2) to delivery casing (101) and tighten the nuts. Ensure that pump shaft rotates freely.
- 6.2.15 Insert gland packing (430) alongwith lantern ring (227) and tighten the gland (223). Do not over tighten it.
- 6.2.16 Fit coupling key (321) and fit pump coupling (390) over shaft.
- 6.2.17 Install the pump on base plate and make suction and delivery as well as auxiliary pipe connections.
- 6.2.18 Fill the oil in bearing housing. Align motor coupling with pump coupling and fix coupling grub screws (653.1 and 653.2)

This completes the reassembly of the pump.

## 7. List of Components, Recommended Stock of Spare Parts & Drawings :

### 7.1 List of Components & Recommended stock of spare parts :

#### For MF & MF-M Pump

Part No.	Description of Part	No. reqd. per Pump
101	Pump casing VDE	1
156*	Semi-open Impeller	1
180+	Pump shaft	1
199*	Shoulder Ring for bearing NDE	1
210	Suction Cover	1
220	Casing Cover	1
223*	Gland (non split type)	1
227*	Lantern Ring (Split in two halves)	1
236*	Liquid Deflector	1
240	Bearing Housing	1
241	Cartridge	1
260.1*	Deep Groove Ball Bearing DE	1
260.2*	Deep Groove Ball Bearing NDE	1
262*	Thrust Ball Bearing DE	1
270*	Bearing Cover DE	1
271	Bearing Cover NDE	1
272	Thrust Bearing Adapter	1
311*	Shaft sleeve	1
320.1+	Key for impeller	1
320.2+	Key for impeller & Shaft Sleeve	1
321+	Key for Coupling	1
330*	Impeller Nut	1
335	Bearing Nut	1
336	Bearing Lock Nut	1
350	Stuffing Box Bush	1
390	Flexible Coupling, Pump Half	1
391	Flexible Coupling, Driver Half	1
410	Lock Washer for Impeller Nut	1
430*	Gland Packing	1 Set
444+	Oil Feeding Plug	1
446	Oil Level Indicator	1
450	Vent Valve	1
470	Inspection Hole Cover for Pump Casing	1
483+	Compression Spring	1 Set
500.1*	Oil Seal for DE Cover	1
500.2*	Oil Seal for NDE Cover	1
514.1*	Gasket for Cartridge and Bearing Cover DE	1
514.2*	Gasket for Bearing Housing and Cartridge	1
514.3*	Gasket for Bearing Housing Cover and Bearing Cover NDE	1
515*	Gasket for Shaft Sleeve & Impeller	1
516*	Gasket (if applicable) for Inspection Hole Cover and Pumps Casing	1
102	Pump Casing H.D.F.	1
104	Pump Casing O.D.F.	1

Part No .	Description of Part	No . reqd. Per Pump
517.5*	Gasket for Part No. 240 & 446	1
518*	Gasket for Part No. 559&101	2
522.1*	'O' Ring for Shaft and Shaft sleeve	1
522.2*	'O' Ring for Suction cover and pump Casing	1
522.3*	'O' Ring for pump casing and casing cover	1
530.1	Pipe Nipple for Stuffing Box Sealing	1
533	Pipe Nipple for Stuffing Box Drain	1
534	Pipe Nipple for Priming	1
540.1	Pipe Coupling Stuffing Box Sealing	2
540.2	Pipe Coupling Stuffing Box	2
550	Wheel Cock for Priming Connection	1
558	Hex. Nuts for Stuffing Box Sealing	2
559	Adaptor for Stuffing Box sealing	2
560	Tube for stuffing Box sealing	1
630.1	Hex. Release Bolts for Suction Cover	2/3/4
630.1	Hex. Release Bolts for Inspection Hole Cover	2
630.2	Hex. Release Bolts for Cartridge	2
630.3	Hex. Release Bolt for Bearing Housing	2
630.4	Hex. Release Bolts for Bearing Cover NDE	2
630.5	Hex. Release Bolts for Casing Cover	2
581.1	Hex. Nut for Part No.596	4/6
581.2	Hex. Nut for Part No.210	8/12/20
581.3	Hex. Nut for Part No.240&101	8/12
581.4	Hex. Nut for Part No.220	8
582	Hex. Nut for Part No. 223	2
586	Hex. Nut for Part No. 270	4/8
590.1	Studs for Pump Casing & Suction Cover	8/12/20
590.3	Studs for Pump Casing and Bearing Housing	8
590.2	Studs for Pump Casing and Bearing Housing	8/12
592	Studs for Gland	2
593	Studs for Bearing Housing Cartridge and Bearing Cover	4/8
596	Studs for Pump Casing and Inspection Hole Cover	4/6
600.1	Pipe Plug for Suction Gauge Connection	1
600.2	Pipe Plug for Delivery Gauge Connection	1
601	Pipe Plug for Pump Casing Drain	1
605	Pipe Plug for Bearing Housing Drain	1
611.3	Pin for Bearing Cover DE Location	1
611.1	Pin for Inspection hole Cover Location	1
653.1	Hex. Socketed Grub Screw for Pump Coupling	1
653.2	Hex. socketed Grub Screw for Driver Coupling	1
657*	CTSK Screw for Bearing Lock Nut	1
792	Hex. Bolts for Stuffing Box Bush	4
654	Hex socket grub screw for Liquid Deflector	1

\*Recommended stock of spare parts for two years operation.

+ Recommended for five years operation.

**7.2.2 Typical Cross Sectional Drawing :**

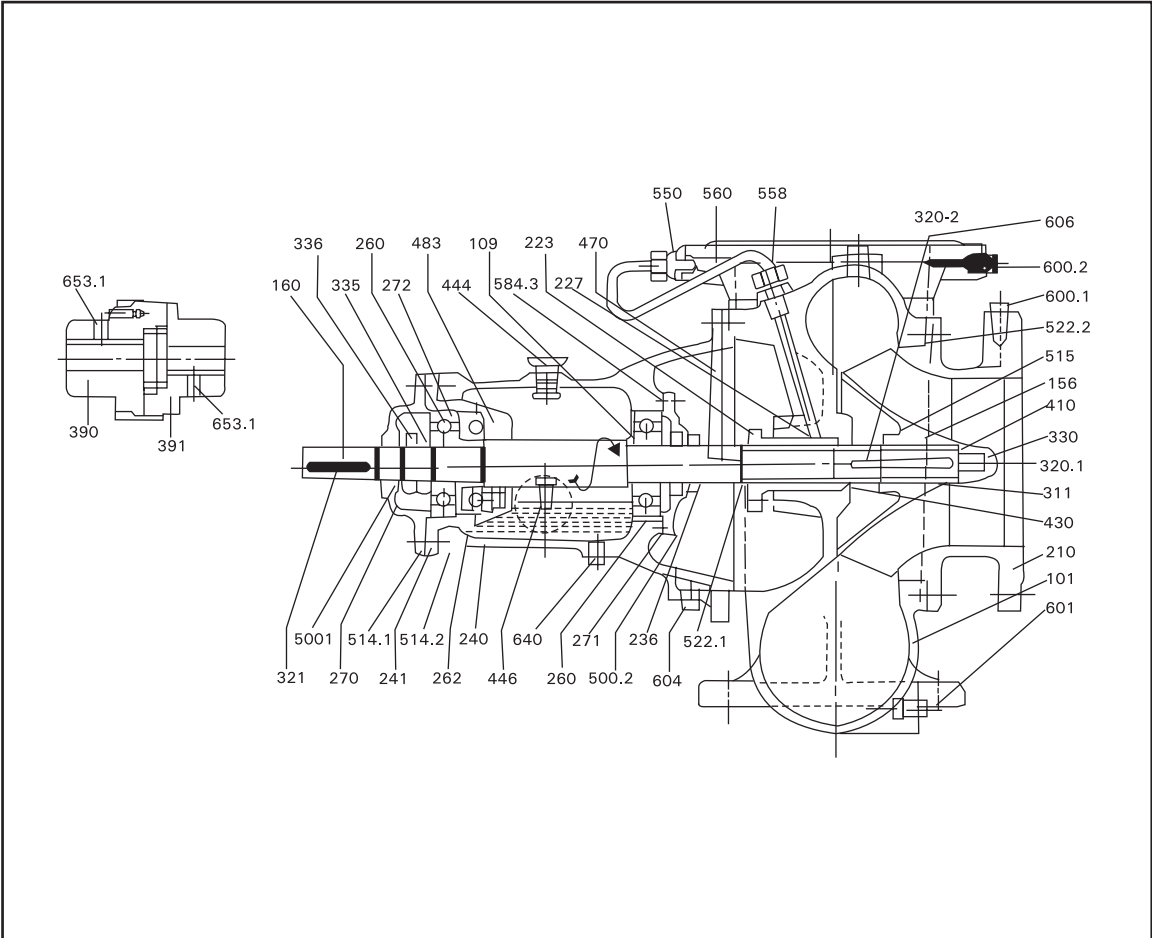

7.2 **List of Components & Recommended stock of spare parts :  
For MFX & MF-E Pump**

Part No.	Description of Part	No. reqd. per Pump
101	Pump casing VDE	1
154*	Enclosed Impeller	1
180 +	Pump shaft	1
199*	Shoulder Ring for bearing NDE	1
210	Suction Cover	1
223*	Gland (non split type)	1
227*	Lantern Ring (Split in two halves)	1
236*	Liquid Deflector	1
240	Bearing Housing	1
241	Cartridge	1
260.1*	Deep Groove Ball Bearing DE	1
260.2*	Deep Groove Ball Bearing NDE	1
262*	Thrust Ball Bearing DE	1
270	Bearing Cover DE	1
271	Bearing Cover NDE	1
272	Thrust Bearing Adapter	1
311*	Shaft sleeve	1
320.1 +	Key or impeller	1
320.2 +	Key for impeller & Shaft Sleeve	1
321 +	Key for Coupling	1
330*	Impeller Nut	1
335	Bearing Nut	1
336	Bearing Lock Nut	1
350	Stuffing Box Bush(only for MFX 40-40, MF 40-40E MF 55-60E)	1
390	Flexible Coupling, Pump Half	1
391	Flexible Coupling, Driver Half	1
410	Lock Washer for Impeller Nut	1
430*	Gland Packing	1 Set
444 +	Oil Feeding Plug	1
446	Oil Level Indicator	1
450	Vent Valve	1
470	Inspection Hole Cover for Pump Casing	1
483 +	Compression Spring	1 Set
500.1*	Oil Seal for DE Cover	1
500.2*	Oil Seal for NDE Cover	1
514.1*	Gasket for Cartridge and Bearing Cover DE	1
514.2*	Gasket for Bearing Housing and Cartridge	1
514.3*	Gasket for Bearing Housing Cover and Bearing Cover NDE	1
168*	Back Vane Plate (Except MFX 20-25)	1
102	Pump Casing H.D.E.	1
104	Pump Casing O.D.E.	1
190*	Casing Ring Suc. Side (Only for MF 25-30E MFX 35-35, 40-40, MF 40-40E, 55-60E)	1
191*	Casing Ring Del. Side (Only for MFX 35-35, 40-40, MF 40-40E, 55-60E)	1



Part No.	Description of Part	No. reqd. per Pump
515*	Gasket for Shaft Sleeve & Impeller	1
516*	Gasket for Inspection Hole Cover and Pump Casing	1
517.5*	Gasket for Part No. 240 & 446	1
518*	Gasket for Part No. 559 & 101	2
522.1*	'O' Ring for Shaft and Shaft Sleeve	1
522.2*	'O' Ring for Suction Cover and Pump Casing	1
534	Pipe Nipple for Priming	1
550	Wheel Cock for Priming Connection	1
654	Hex. socket Grub Screw for Liquid Deflector	1
630.1	Hex. Release Bolts for Suction Cover	2/3/4
630.1	Hex. Release Bolts for Inspection Hole Cover	2
630.2	Hex. Release Bolts for Cartridge	2
630.3	Hex. Release Bolts for Bearing Housing	2
630.4	Hex. Release Bolts for Bearing Cover NDE	2
581.1	Hex. Nut for Part No. 596	4/6
581.2	Hex. Nut for Part No. 210	8/12/20
581.3	Hex. Nut for Part No. 240 & 101	8/12
582	Hex. Nut for Part No. 223	2
586	Hex. Nut for Part No. 270	4/8
590.1	Studs for Pump Casing & Suction Cover	8/12/20
590.2	Studs for Pump Casing and Bearing Housing	8/12
592	Studs for Gland	2
593	Studs for Bearing Housing Cartridge and Bearing Cover	4/8
596	Studs for Pump Casing and Inspection Hole Cover	4/6
600.1	Pipe Plug for Suction Gauge Connection	1
600.2	Pipe Plug for Delivery Gauge Connection	1
601	Pipe Plug for Pump Casing Drain	1
605	Pipe Plug for Bearing Housing Drain	1
611.3	Pin for Bearing Cover DE Location	1
611.1	Pin for Inspection hole Cover Location	1
653.1	Hex. Socketed Grub Screw for Pump Coupling	1
653.2	Hex. Socketed Grub Screw for Driver Coupling	1
657*	CTSK Screw for Bearing Lock Nut	1
792	Hex. Bolts for Stuffing Box Bush	4
791	Hex. Socket Cap Screw for Back Vane Plate (Except MFX 20-25)	4/8
441	Grease Nipple for Grease Sealing	1
522.3	'O' Ring for Back Vane Plate	1
522.4	'O' Ring for Back Vane Plate	1
611.2	Pin for Back Vane Plate	1
650	Hex Socket Grub Screw for Casing Ring (Only for MFX 35-35, 40-40, MF 40-40E, MF 55-60E)	2

\*Recommended stock of spare parts for two years operation.

+ Recommended for five years operation.

## 8.0 GENERAL

### Instructions on Installation, Operation and Maintenance for MF 200 Pump

- 8.1 These are single stage, horizontal spindle volute type foot mounted end suction pumps fitted with grease lubricated ball bearings. The pumps are provided with enclosed type mixed flow impeller. The delivery casing can be offered in following two different execution.
- 1) MEGHA - (Standard) Pointing Vertical upwards.
  - 2) MRUGA - Pointing horizontal.
- 8.2 Pumps when properly installed and given due care in operation and maintenance should operate satisfactorily for a long period.
- 8.3 When the pump is received some time before the actual use of pump, it should be inspected and located in dry place. The coupling should be rotated once in a month to prevent pitting of bearing surfaces.
- 8.4 The special problems arising at site should be referred to the supplier. Full name plate details should be furnished while exchanging correspondence in connection with these pumps.

## 9. INSTALLATION :

- 9.1 For location, preparing foundation, installation, alignment, general maintenance, trouble shooting etc. the instructions given in our publication General instruction Manual on centrifugal pumps which is printed alongwith this manual must be followed carefully.

## 10. OPERATION :

### 10.1 Before starting the pump, check the following :

- 10.1.1 The pump rotates freely.
- 10.1.2 Sealing connection if any is properly tightened and adjusted.
- 10.1.3 Oil level in the bearing housing.
- 10.1.4 The direction of rotation of motor corresponds to the direction of rotation of the pump.
- 10.1.5 The pump and suction pipe is fully primed with the liquid.
- 10.1.6 Stuffing box is packed properly and gland is tightened.
- 10.1.7 Valve on delivery side is closed.
- 10.1.8 The cock fore pressure gauge connection is closed.

### 10.2 Starting the pump :

- 10.2.1 Open delivery valve 30% approx of full open.
- 10.2.2 Start the motor. Let the prime mover pick up its full speed.
- 10.2.3 Open the valve on delivery side fully.

- 10.2.4 Open the cock for pressure gauge connection.
- 10.3 **During running of pump, check the following and regulate if necessary :**
  - 10.3.1 The pump and motor is running smooth.
  - 10.3.2 The flow of sealing liquid is uninterrupted if external sealing is applicable.
  - 10.3.3 Leakage through stuffing box is normal. There should be leakage of 60 to 80 drops per minute.
  - 10.3.4 The bearings not getting heated up excessively.
  - 10.3.5 Head and capacity developed by the pump is as specified.
  - 10.3.6 Power consumption is within limit.
  - 10.3.7 Ensure that there is no mechanical friction in the pump.
  - 10.3.8 Stop the pump immediately if any defects are noticed. DO NOT START IT AGAIN UNLESS DEFECTS ARE RECTIFIED. REPORT IMMEDIATELY TO THE SUPPLIER IF IT IS NOT POSSIBLE TO RECTIFY THE DEFECTS.
- 10.4 **Stopping the pump :**
  - 10.4.1 Close the valve on delivery side.
  - 10.4.2 Stop the motor.
  - 10.4.3 Close the sealing connection.
  - 10.4.4 If the pump is not required to be operated for long time drain the casing completely. Also drain the lubrication grease completely. The bearing housing should be dried internally with hot air and should be flushed with moisture free protective such as light oil or kerosene.
- 11. **TECHNICAL DATA :**
  - 11.1 **Direction of rotation :**

The standard direction of rotation is clockwise when viewed from driving end. The pump with reverse direction of rotation is not possible.
  - 11.2 **Bearings :**

The pumps are fitted with antifriction heavy duty single row deep groove ball bearings at driving and non driving end. Bearings used are SKF 6307. However, equivalent bearings in type, capacity and dimensions also can be used.
  - 11.3 **Lubrication :**

Bearings are grease lubricated. Properties of grease are : a) Soap Lithium. b) Colour-brown c) Structure-smooth, d) Penetration at 25<sup>o</sup>C (60 strokes) 200-250, e) Drop Point - 180<sup>o</sup>C.

11.3.1 Type of Grease :

Manufacturer	Trade Name
I.O.C.L.	SERVOGEM-3
H.P.C.L.	NATRA OR LITHON-3

11.3.2 Period of lubrication - After 1000 hrs. of running.

11.3.3 Max. allowable bearing temperature is 80°C.

11.3.4 Qty. of grease-10 gms per bearing.

11.4 **Stuffing box :**

The stuffing boxes are extra deep to reduce leakage and minimize the maintenance. Split lantern ring is provided for sealing purpose.

11.5 **Sealing :**

Self liquid only is used for sealing in most of the cases. However sealing arrangement with external liquid can be supplied against specific request.

11.5.1 Pressure & Quantity of water required for stuffing box sealing when supplied from external source.

The water should be at pressure of one atmosphere above the pressure developed by the pump water quantity : 5 litres / minute.

11.6 **Stuffing box packing :**

Champion style '3116' Graphited cotton is used in the standard supply. However packing suitable for liquid handled is also supplied against order.

Size of stuffing box packing - 8 mm square  
Length of stuffing box packing - 515 mm  
No. of packing & Lantern Ring position from impeller side - 1 + L + 4

11.7 **Flexible Coupling :**

Love Joy coupling type SW-150

11.8 **Flange size :**

Delivery : 200 mm  
Suction : 200 mm

12 **MAINTENANCE :**

Preventive maintenance schedule is the periodical checks and precautions by which possibilities of failure and break down are made very remote.

12.1 **Daily Checks :**

12.1.1 Pressure gauge readings.

12.1.2 Bearing temperature.

12.1.3 Leakage through st. box.

12.1.4 Noise and vibrations.

12.1.5 Voltage and current.

1.2.2 **Periodical checks :**

12.2.1 Replenish the grease.

12.2.2 Change the stuffing box packing.

12.2.3 Check the alignment of pumpset.

12.2.4 Caliberate the measuring instruments.

12.2.5 Check the sealing connections.

**13. OVERHAULING :**

With normal daily operating spell, the pump will be due for overhaul after about 5000 working hours. This work should be done by skilled personnel. Please refer to the cross sectional drawing while dismantling and reassembling the pump.

**13.1 Dismantling :**

Drain the delivery casing completely by removing drain plug (601).

13.1.1 Disconnect the pump from suction and delivery piping and auxiliary piping if any. Remove coupling grub screws. Unscrew the bolts holding the pump on base plate and take out the pump.

13.1.2 Remove vent valve (450) and pump coupling (390). Take out coupling key (321).

13.1.3 Remove the nuts holding down bearing housing (240) from delivery casing (101). Take out bearing housing alongwith impeller (154) by tightening release bolts.

13.1.4 Unscrew impeller nut (330). Take out the lock washer (410) for impeller nut.

13.1.5 Remove the impeller (154) from pump shaft.

13.1.6 Take out impeller key (320)

13.1.7 Unscrew gland nuts. Take out gland packing (430) and lantern ring (227).

13.1.8 Remove bearing cover DE (270) by removing bolts and bearing end cap (273).

13.1.9 Take out shaft (180) from bearing housing alongwith ball bearing (260) DE and NDE. Take out gland, liquid deflector and bearing end cap.

13.1.10 Remove ball bearing DE and NDE (260) and take out shoulder ring (199). Take out casing ring (190) from delivery casing.

This completes the dismantling of the pump.

Before proceeding with reassembly of rotating unit and pump, check the following :

A) Ball bearings are rotating freely and smoothly. Renew them if they are not rotating freely or if the races are deteriorated.

B) Check the shaft for possible run out. Remove the same before reassembly.

- C) Remove any dust or rust from parts and if necessary apply new paint/coating on the same.
- D) Clean all the parts thoroughly with kerosene or petrol.
- E) If reassembly is not to be made immediately, apply rust preventive, coating on all machined surfaces.
- F) Examine all the parts for refitting worn out etc. Damaged or corroded parts should be replaced by new.
- G) Ensure that newly fitted parts are free from damage and from burrs.
- H) Examine deflector for damage or deterioration. If replaced with new make sure that they are of requisite dimensions.
- f) Check clearance between casing ring and impeller. The clearance should be within the max. and min. limit.

Max. - 0.66 mm

MIN. - 0.47 mm

### 13.2 Reassembly :

13.2.2 Wipe light clean oil over shaft (180).

13.2.1 Insert shoulder ring (199) and fit ball bearings (260) DE and NDE.

13.2.3 Lift the shaft (180) duly fitted with bearings and insert it in bearing housing (240) alongwith bearing end cap (273), liquid deflector (236) and gland (223).

13.2.4 Fit bearing cover DE (270) and bearing end cap (273)

13.2.5 Fit impeller key (320) and fit the impeller (154)

13.2.6 Insert lockwasher for impeller nut (410) over pump shaft (180) and tighten impeller nut (330). Lock the impeller nut by means of lock washer.

13.2.7 Ensure that impeller rotates freely . Fit casing ring (190) in the delivery casing . Fit bearing housing (240) alongwith impeller (154) to delivery casing (101) and tighten the nuts.

13.2.8 Insert gland packing (430) alongwith lantern ring (227) and tighten the gland. Do not over tighten it .

13.2.9 Fit coupling key (321) and fit pump coupling (390) over shaft. Fit vent valve (450) on delivery casing.

13.2.10 Install the pump on base plate and make suction and delivery as well as auxiliary pipe connectors.

13.2.11 Fill the grease in bearing housing. Fit grease nipples (441). Align motor coupling with pump coupling and fix coupling grub screws.

This completes the reassembly of the pump.

14 LIST OF COMPONENTS, RECOMMENDED STOCK OF SPARE PARTS & DRAWINGS :

14.1 List of components & recommended stock of spare parts :

PART NO.	DESCRIPTION OF PART	NO. REQD. PER PUMP
101	Pump Casing	1
154*	Impeller	1
180 +	Shaft	1
190*	Wear Ring	1
199*	Shoulder Ring	2
206	Collar	1
223	Gland	1
227	Lantern Ring	1
236*	Liquid Deflector	1
240	Bearing Housing	1
260*	Ball Bearing SKF 6307 or eq. DE/NDE	2
270	Bearing Cover	1
273	Bearing End Cap	1
320 +	Impeller Key	1
321 +	Coupling Key	1
330 +	Impeller Nut	1
390	Pump Coupling	1
391	Driver Coupling	1
410	Lock Washer for Impeller Nut	1
430*	Gland Packing	1
441	Grease Nipple	2
450	Vent Valve	1
601	Drain Plug for Pump Casing	1
653.1	Grub Screw for Pump Coupling	1
653.2	Grub Screw for Driver Coupling	1
687*	Gasket for Pump Casing	1
984*	Snap Wrap	1
988	Cheese Head Screw	1

\*Recommended stock of Spare Parts for 2 years operation.

+ Recommended for 5 years operation.

14.2 GROSS SECTIONAL ASSEMBLY OF MF 200 PUMP :

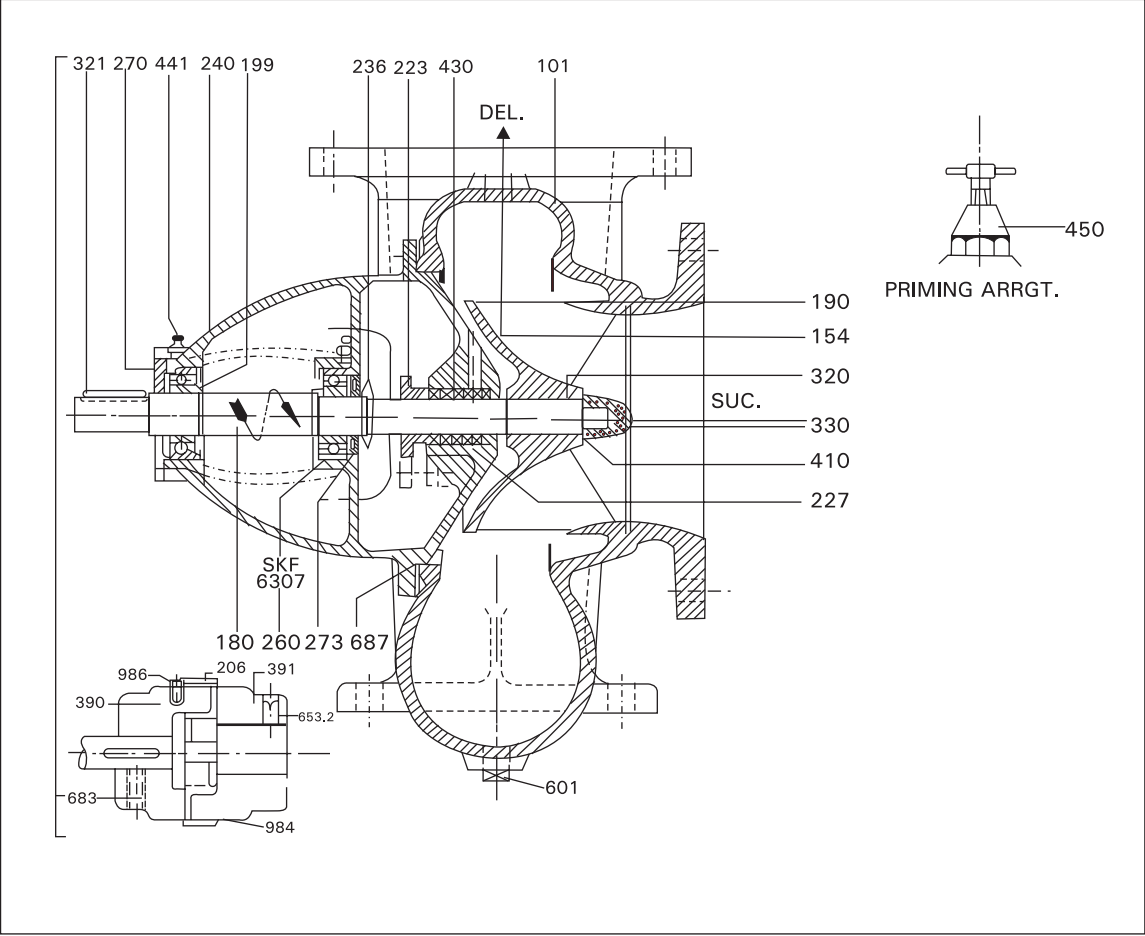



# NOTES

A series of horizontal dotted lines for writing notes, spanning the width of the page.

## **GENERAL INFORMATION & SAFETY INSTRUCTIONS**

- 1.0 The products supplied by KBL have been designed with safety in mind. Where hazards cannot be eliminated, the risk has been minimised by the use of guards and other design features. Some hazards cannot be guarded against and the instructions below **MUST BE COMPLIED WITH** for safe operation. These instructions cannot cover all circumstances, **YOU** are responsible for using safe working practices at all times.
- 1.1 KBL products are designed for installation in designed area, which are to be kept clean and free of obstructions that may restrict safe access to the controls and maintenance access points.  
  
A Pump Duty Nameplate is fitted to each unit and must not be removed. Loss of this plate could make identification impossible. This in turn could affect safety and cause difficulty in obtaining spare parts. If accidental loss or damage occur, contact KBL immediately.
- 1.2 Access to the equipment should be restricted to the personnel responsible for installation, operation and maintenance and they must be trained, adequately qualified and supplied with appropriate tools for their respective tasks.
- 1.3 KBL requires that, all personnel that are responsible for installation, operation or maintenance of the equipment, have access to and study the product instruction manual **BEFORE** any work is done and that they will comply with all local and industry based safety instructions and regulations.
- 1.4 Ear defenders should be worn where the specified equipment noise level exceeds locally defined safe levels. Safety glasses or goggles should be worn where working with pressurised systems and hazardous substances. Other personnel protection equipment must be worn where local rules apply.
- 1.5 Do not wear loose clothing or jewellery which could catch on the controls or become trapped in the equipment.
- 1.6 Read the instruction manual before installation, operation or maintenance of the equipment. Check and confirm that the manual is relevant copy by comparing pump type on the nameplate and with that on the manual.
- 1.7 Note the 'Limits of product application- permissible use' specified in the manual. Operation of the equipment beyond these limits will increase the risk from hazards noted below and may lead to premature and hazardous pump failure.
- 1.8 Clear and easy access to all controls, gauges and dials etc. must be maintained at all times. Hazardous or flammable materials must not be stored in pump rooms unless safe areas or racking and suitable containers have been provided.
- 1.9 **IMPROPER INSTALLATION, OPERATION OR MAINTENANCE OF THIS KBL PRODUCT COULD RESULT IN INJURY OR DEATH.**

### **2.0 SAFETY INSTRUCTIONS WHILE HANDLING AND STORAGE**

When lifting the pump, use the lifting points specified on general arrangement drawing. Use lifting equipment having a safe working load rating suitable for the weight specified. Use suitable slings for lifting pump which is not provided with lifting points. The use of fork-lift truck and chain crane sling equipment is recommended but locally approved equipment of suitable rating may be used.

Do not place fingers or hands etc. into the suction or discharge pipe outlets and do not touch the impeller, if rotated this may cause severe injury. To prevent ingress of any objects, retain the protection covers or packaging in place until removal is necessary for installation. If the packaging or suction and discharge covers are removed for inspection purposes, replace afterwards to protect the pump and maintain safety.

### **3.0 SAFETY INSTRUCTIONS WHILE ASSEMBLY & INSTALLATION**

Do not place fingers or hands etc. into the suction or discharge pipe outlets and do not touch the impeller, if rotated this may cause severe injury. To prevent ingress of any objects, retain the protection covers or packaging in place until removal is necessary for installation.

Do not touch any moving or rotating parts. Guards are provided to prevent access to these parts, where they have been removed for maintenance they must be replaced before operating the equipment.

Shaft alignment must be checked again after the final positioning of the pump unit and connection to pipework as this may have disturbed the pump or motor mounting positions. If hot liquids (above 80°C) are being pumped, alignment should be checked and reset with the pump and motor at their normal operating temperature. If this is not possible, KBL can supply estimated initial offset figures to suit extreme operating temperatures.

Failure to support suction and delivery pipework may result in distortion of the pump casing, with the possibility of early pump failure.

### **4.0 SAFETY INSTRUCTIONS WHILE COMMISSIONING & OPERATION**

Do not touch any moving or rotating parts. Guards are provided to prevent access to these parts, where they have been removed for maintenance they must be replaced before operating the equipment.

Check that the pump is primed. Pump should never be run dry as the pumped liquid acts as lubricant for the close running fits surrounding impeller and damage will be incurred.

Failure to supply the stuffing box or mechanical seal with cooling of flush water may result in damage and premature failure of the pump.

Do not touch surfaces which during normal running will be sufficiently hot to cause injury. Note that these surfaces will remain hot after the pump has stopped, allow sufficient time for cooling before maintenance. Be cautious and note that other parts of the pump may become hot if a fault is developing.

Do not operate water pumps in temperatures below freezing point, without first checking that the pumped fluid is not frozen and the pump is free to turn. Pumps in these environments should be drained down during inactivity and re-primed before starting.

In addition to local or site regulations for noise protection, KBL recommend the use of personal ear protection equipment in all enclosed pump rooms and particularly those containing diesel engines. Care must be taken to ensure that any audible alarm or warning signal can be heard with ear defenders worn.

Be aware of the hazards relating to the pumped fluid, especially the danger from inhalation of noxious and toxic gases, skin and eye contact or penetration. Obtain and understand the hazardous substance data sheets relating to the pumped fluid and note the recommended emergency and first aid procedures.

## 5.0 SAFETY INSTRUCTIONS WHILE MAINTENANCE & SERVICING

Before attempting any maintenance on a pump particularly if it has been handling any form of hazardous liquid, it should be ensured that the unit is safe to work on. The pump must be flushed thoroughly with suitable cleaner to purge away any of the product left in the pump components. This should be carried out by the plant operator and a certificate of cleanliness obtained before starting work. To avoid any risk to health it is also advisable to wear protective clothing as recommended by the site safety officer especially when removing old packing which may be contaminated.

Check and ensure that the pump operates at below the maximum working pressure specified in the manual or on the pump nameplate and before maintenance, ensure that the pump is drained down.

Wear a suitable mask or respirator when working with packing and gasket components which contain fibrous material as these can be hazardous when the fibrous dust is inhaled. Be cautious, if other supplier's components have been substituted for genuine KBL parts, these may then contain hazardous materials.

Be aware of the hazards relating to the pumped fluid, especially the danger from inhalation of noxious and toxic gases, skin and eye contact or penetration. Obtain and understand the hazardous substance data sheets relating to the pumped fluid and note the recommended emergency and first aid procedures.

Isolate the equipment before any maintenance work is done. Switch off the mains supply, remove fuses, apply lock-outs where applicable and affix suitable isolation warning signs to prevent inadvertent reconnection. In order to avoid the possibility of maintenance personnel inhaling dangerous fumes or vapours, it is recommended that the maintenance work be carried out away from the pump locations by removal of bearing housing and shaft assembly to a suitable maintenance area.

---

Ref. : Proposed draft standard prEN 800 :  
Pumps and pump units for liquids;  
General safety requirements.

INCORRECT

CORRECT

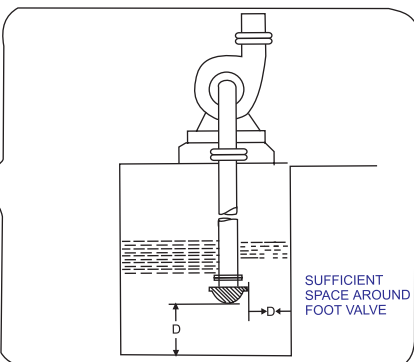
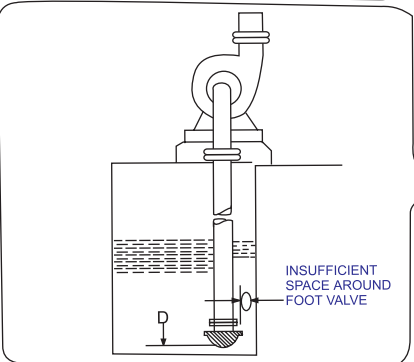
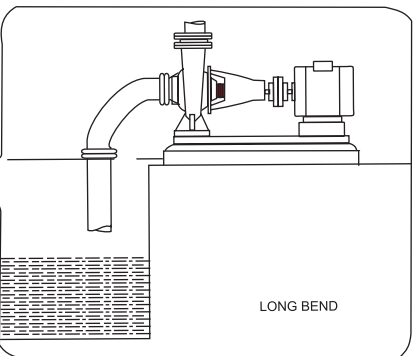
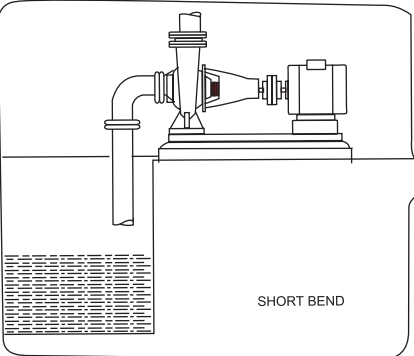
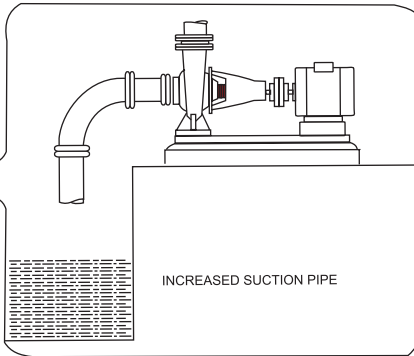
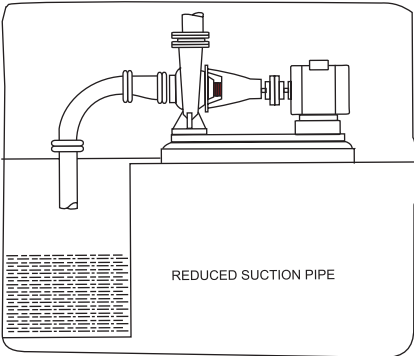
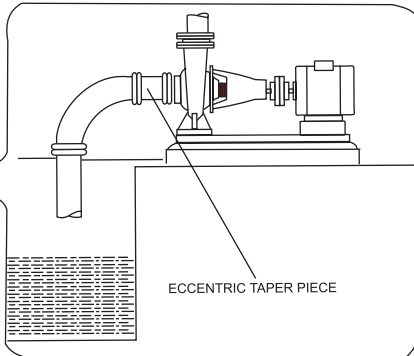
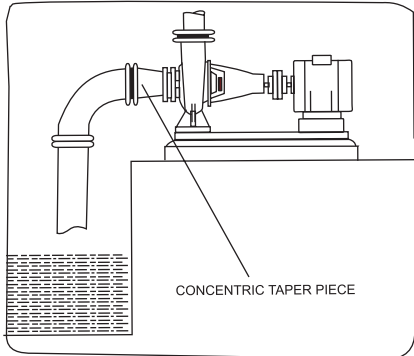
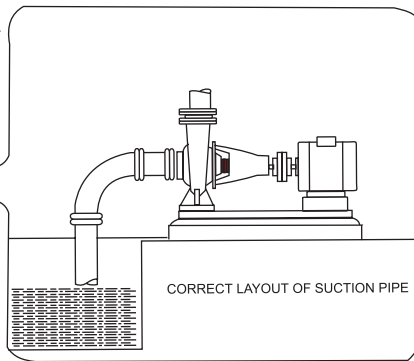
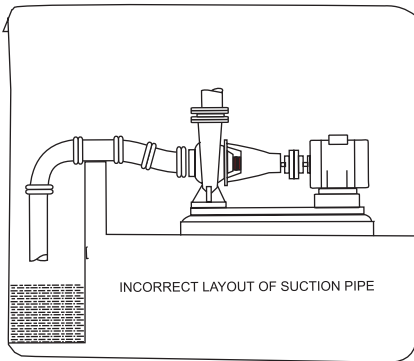

FOR RECOMMENDATIONS OF SUITABLE SUCTION AND DELIVERY PIPE SIZE PLEASE CONTACT OUR AUTHORISED DEALER OR NEAREST REGIONAL OFFICE

# GENERAL INSTRUCTIONS FOR INSTALLATION OPERATION & MAINTENANCE OF KIRLOSKAR CENTRIFUGAL PUMPS

# GENERAL INSTRUCTIONS FOR INSTALLATION, OPERATION & MAINTENANCE OF KIRLOSKAR CENTRIFUGAL PUMPS

## WARNING

The equipment supplied is designed for specific capacity, speed, pressure and temperature. Do not use the equipment beyond the capacities for which it is manufactured. The equipment manufactured is also shop tested for the satisfactory performance and if it is operated in excess of the conditions for which it is manufactured, the equipment will be subject to excessive stresses and strains.

## LOCATION

The pump should be located as near the liquid source as possible. This will minimise the suction lift and pump will give better performance.

Ample space should be provided on all the sides so that the pump can be inspected while in operation and can be serviced conveniently whenever required.

## FOUNDATION

The foundation should be sufficiently substantial to absorb any vibration and to form a permanent rigid support for the base plate. This is important in maintaining the alignment of a direct connected unit. A concrete foundation on a solid base is advisable. Foundation bolts of the proper size should be embedded in the concrete located by a drawing or template. A pipe sleeve about two and one-half diameter larger than the bolt should be used to allow movement for the final position of the foundation bolts.

## ALIGNMENT

Pumps and drivers that are supplied by the manufacturers, mounted on a common base plate are accurately aligned before despatch. However as the alignments are likely to be disturbed during transit to some extent and therefore must not be relied upon to maintain the factory alignment. Re-alignment is necessary after the complete unit has been levelled on the foundation and again after the grout has been set and foundation bolts have been tightened. The alignment must be checked after the unit is piped up and re-checked periodically.

## FLEXIBLE COUPLING

A flexible coupling will not compensate for misalignment of the pump and driver shafts. The purpose of the flexible coupling is to compensate for temperature changes and to permit the movement of the shafts without interference with each other while transmitting power from the driver to the pump.

## TYPE OF MISALIGNMENT (SEE FIGURE 1)

There are two types of misalignment between the pump shaft and the driver shaft.

- Angular misalignment : Shafts with axis concentric but not Parallel.
- Parallel misalignment : Shafts with axis Parallel but not concentric.

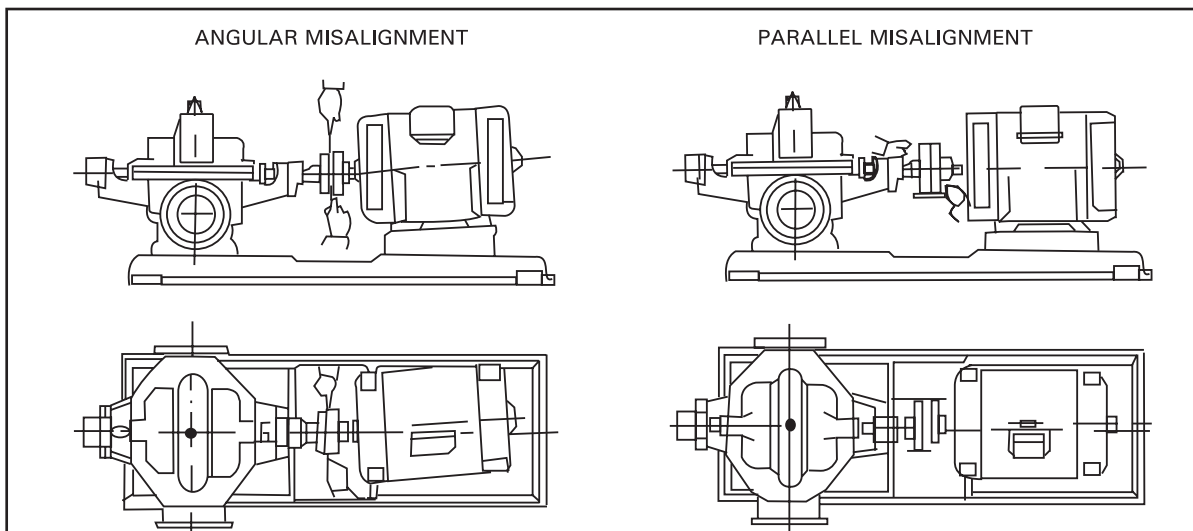

## LEVELLING THE UNIT

When the unit is received with the pump and driver mounted on the base plate, it should be placed on the foundation and the coupling halves disconnected. The coupling should not be reconnected until all alignment operations have been completed. The base plate must be supported evenly on wedges inserted under the four corners so that it will not be distorted or sprung by the uneven distribution of the weight. Adjust the wedges until the shafts of the pump and driver are in level. Check the coupling faces, suction and discharge flanges for the horizontal or vertical position by means of spirit level.

## FLEXIBLE COUPLING ALIGNMENT (SEE FIGURE 2)

The two halves of the coupling should be at least 4 mm apart so that they cannot touch each other when the driver shaft is rotated. Necessary tools for approximately checking are straight-edge and an outside caliper.

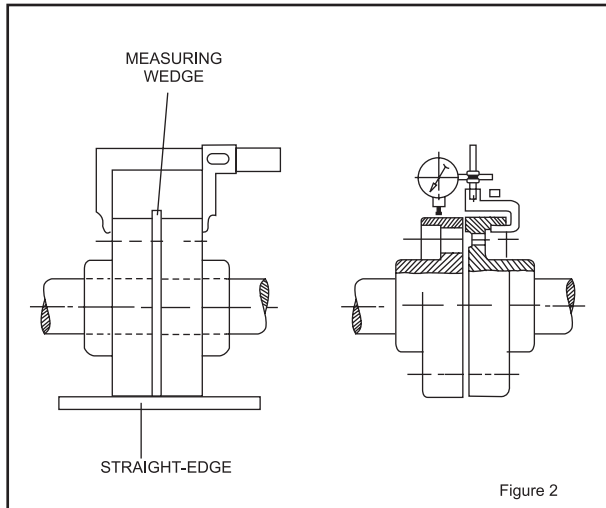
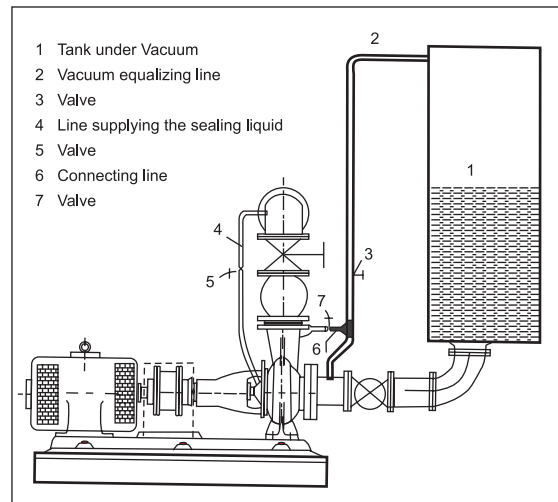

Figure 2



A check for parallel alignment is made by placing a straight-edge across both coupling periphery at the top, bottom and both the sides. The unit will be in parallel alignment when the straight-edge rests evenly on the coupling periphery at all positions. Care must be taken to have the straight-edge parallel to the axis of the shafts.

A check for angular alignment is made by using an outside caliper across the width of the coupling faces at various points.

Coupling alignment can be checked with dia gauge indicator as shown in Fig. 2.

### GROUTING

When the alignment is correct, the foundation bolts should be tightened evenly but not too firmly. The unit can then be grouted by working soft concrete under the edges. Foundation bolts should not be fully tightened until the grout is hardened, usually 48 hours after pouring.

### FACTORS THAT MAY DISTURB ALIGNMENT

The unit should be periodically checked for alignment. If the unit does not stay in line after being properly installed, the following are possible causes :

- a) Setting, seasoning of the foundation.
- b) Pipe strains distorting or shifting the machines.
- c) Wear of the bearings.

### PIPING

Both suction and delivery pipes and accessories should be independently supported near the pump so that when the flanges bolts are tightened no strain will be transmitted to the pump casing. It is usually advisable to increase the size of both suction and delivery pipes at the pump nozzles in order to decrease the loss of head from friction and for the same reason piping should be arranged with as minimum bends as possible as these should be made with a long radius wherever possible. The pipe lines should be free from scales, welding residuals etc., and have to be mounted in such a way that they can be connected to suction and delivery flanges without any stress on the pump. Adequate supports should be given to pipe lines so that the weight of the pipe lines does not fall on the pump. The use of minimum number of the bends and other fittings will minimise the frictional losses.

### SUCTION PIPE

The suction pipe should be as short as possible. This can be achieved by placing the pump near the liquid to be pumped. The suction pipe must be kept free from air leaks. This is particularly important when the suction lift is high. A horizontal suction line must have a gradual rise to the pump. Any high point in the pipe will be filled with air and thus prevent proper operation of the pump. A concentric taper piece should not be used in a horizontal suction line as it forms an air pocket in the top of the reducer and the pipe. Use an eccentric piece instead.

The end of the suction pipe must be well submerged to avoid whirlpools and ingress of air but must be kept clear of any deposits of mud, silt grit etc. The pipe must be clear from any side of wall by atleast 450 mm. The end of the suction pipe should be provided with a strainer or sufficient open area.

### DELIVERY PIPE

A check (non-return) valve and a gate or sluice valve (regulating valve) should be installed in the discharge line. The check valve placed between the pump and the gate valve is to protect the pump from excessive pressure and to prevent water running back through the pump in case of failure of the driving machine.

Discharge piping should be provided with a sluice valve adjacent to the delivery flange to control the discharge, if required.

### VACUUM EQUALIZING LINE(AND LIQUID LINE) (SEE FIGURE 3)

If the pump draws from a system under vacuum an equalizing pipe must be carried from the highest point of the suction line, however, as close to the suction flange of the pump as possible, to the top of the feed tank to keep gas bubbles that might have been entrapped in the flow from entering the pump. The line should be fitted with an isolating valve which should be closed only for maintenance work on the pumpset.

Apply sealing liquid (external sealing) to the shaft seal cage to prevent entry of air in the case of pumps with packed stuffing box. It is convenient to tap the sealing liquid from the delivery line above the non-return valve.

## **FOOT VALVE**

It is advisable to install a foot valve to facilitate priming. The foot valve should have sufficient clear passage for water. Care must be taken to prevent foreign matter from being drawn into the pump or choking the foot valve and for this purpose an efficient strainer should be provided.

## **STUFFING BOXES AND PACKING**

Stuffing boxes should be carefully cleaned and the packing placed in them. Be sure that sufficient packing is placed at the back of the water seal cage. If the water to be pumped is dirty or gritty, sealing water should be piped to the stuffing boxes from clean outside source of supply in order to prevent damage to the packing and shaft. In placing the packing, each packing ring should be cut to the proper length so that ends come together but do not overlap. The succeeding rings of packing should not be pressed too tight as it may result in burning the packing and cutting the shaft. If the stuffing box is not properly packed, friction in stuffing box prevents turning the rotor by hand. On starting the pump it is well to have the packing slightly loose without causing an air leak, and if it seems to leak, instead of putting too much pressure on the gland, put some heavy oil in the stuffing box until the pump works properly and then gradually tighten up the gland. The packing should be occasionally changed.

## **BALL BEARINGS**

Correct maintenance of ball bearings is essential. The bearing manufacturers give the following as a guide to relubrication periods under normal conditions.

Three monthly when on continuous duty.

Six monthly when on eight-hour per day duty.

The bearing and housings should be completely cleaned and recharged with fresh grease after 2500 hours or the nearest pump overhaul time.

## **PRIMING**

No pumping action occurs unless the pump casing is filled with liquid. Pump casing and suction pipe must therefore be completely filled with the liquid and thus all air removed before the pump is started. Several different priming methods can be used depending on the kind of installation and service involved.

- 1) Liquid level above pump level.  
Pump is set below liquid level of source of supply so that liquid always flows to pump under positive head.
- 2) Priming with Foot Valve
  - a) When pump is installed on suction lift with foot valve at the end of suction line, fill pump with water from some outside source till all air is expelled and water flows through air vent.
  - b) when there is liquid under some pressure in the discharge pipe, priming can be effected by bypassing the pressure liquid around the check and gate valve. Of course, the initial priming must be effected from some outside source.  
NOTE : In this case, the foot valve must be capable of withstanding pump pressure and possible surge.
- 3) Priming by ejector : An ejector operated by steam, compressed air or water under pressure and connected to air vent on top of casing can be used to remove air from and prime the pump on suction lift installations.
- 4) Priming by dry vacuum pump : A hand or power pump sucks in all the air from the casing and the suction pipe, and thus primes the system.

## **STARTING**

The pump must not be started without being primed. Be sure that the driver rotates in the proper direction as indicated by a direction arrow on the pump casing.

## **RUNNING**

On account of its simple construction, the centrifugal pump requires practically no attention while running. Lubrication of the bearings and manipulation of the glands are the only things that need attention from the operator.

## **STOPPING**

Before stopping the pump, close the gate valve. This will prevent water hammer on check valve.

## **STUFFING BOXES**

Do not tighten the glands excessively. A slight dripping of water from the stuffing boxes when pump is running keeps packing in good condition.

## **CASING RINGS**

Casing rings are fitted in the casing to reduce the quantity of water leaking back from the high pressure side to the suction side. These casing rings are fitted to maintain a small clearance and depend on the water in the pump for lubrication. When they are worn out, the clearance becomes greater and more water passes back into the suction. They must be replaced from time to time to restore the pump efficiency to its normal value.



## SPARE PARTS

A set of ball bearings, a set of casing rings and a set of gland packing rings must always be kept at hand to ensure uninterrupted service from the pump. While ordering for spare parts, always give type, size and serial number of the pump as stamped on the name plate.

## PUMP TROUBLE

When investigating trouble with Kirloskar pumps, always remember that pumps have been tested at the factory and are mechanically correct when sent out. Discounting the possibility of damage during transit, most of the trouble in the field is due to faulty installation. Investigation shows that the majority of troubles with centrifugal pumps result from faulty conditions on the suction side.

## BREAKDOWN-CAUSE-CHECK POINTS

In case of breakdown we recommend the location of the fault by using the following table.

BREAKDOWN	CHECK POINTS																										
Pump does not deliver	1	7	8	9	10	11	12	14	15	17	18	19	23	25	26	56	57	58									
Pump delivers at reduced capacity	1	2	3	4	5	6	7	8	9	10	11	12	13	14	15	17	18	19	20	21	22	56	57	58			
Delivery performance deteriorates	1	3	7	9	10	11	12	13	14	19	20	21	22	23	24	53	57	62									
Pump delivers too much	16	56	57	58																							
Delivery is interrupted	1	3	6	7	8	9	10	11	12	13	14	15	16	19	22	23	25	26	56	57	58	62					
After stopping pump runs in reverse direction	52																										
Very noisy	1	2	5	6	7	8	11	12	13	15	19	20	22	54	55	56	57	62									
Unsteady running of pump	19	20	22	31	32	33	35	36	37	38	39	40	43	44	47	48	49	50	51	54	55	58					
Stuffing box leaks excessively	24	27	28	29	30	31	47	48	49	53																	
Fumes from stuffing box	22	23	24	25	26	27	28	29	30	41	42	43															
Pump rotor locked in standstill position	22	45	46	50																							
Pump is heating up and seizing	23	24	25	26	27	28	29	30	40	41	42	45	46	47	48	49	50	54									
Bearing temperature increases	19	20	21	22	31	32	33	34	35	36	37	38	39	40	41	42	43	44	45	46	47	48	49	51	54	55	58
Motor will not start	14	22	60																								
Motor gets hot or burns out	14	22	27	28	40	43	50	55	56	57	58	59	60	61													
Motor is difficult to start	14	22	27	28	45	46	50	58	59	60																	

# CHECK POINTS

- 1 Suction pipe, foot valve choked.
- 2 Nominal diameter of suction line too small.
- 3 Suction pipe not sufficiently submerged.
- 4 Too many bends in the suction line.
- 5 Clearance around suction inlet not sufficient.
- 6 Shut off valve in the suction line in unfavourable position.
- 7 Incorrect layout of suction line (formation of air pockets)
- 8 Valve in the suction line not fully open.
- 9 Joints in the suction line not leak-proof.
- 10 Air leaking through the suction line & stuffing box etc.
- 11 Suction lift too high.
- 12 Suction head too low (difference between pressure at suction connection and vapour pressure too low).
- 13 Delivery liquid contains too much gas and/or air.
- 14 Delivery liquid too viscous.
- 15 Insufficient venting.
- 16 Number of revolutions too high.
- 17 Number of revolutions too low.
- 18 Incorrect direction of rotation (electric motor incorrectly connected, leads of phases on the terminal block interchanged)
- 19 Impeller clogged.
- 20 Impeller damaged.
- 21 Casing rings worn out.
- 22 Separation of crystals from the flow of pumping liquid (falling below the temperature limit/equilibrium temp).
- 23 Sealing liquid line obstructed.
- 24 Sealing liquid contaminated
- 25 Lantern ring in the stuffing box is not positioned below the sealing liquid inlet.
- 26 Sealing liquid omitted.
- 27 Packing incorrectly fitted.
- 28 Gland tightened too much/slanted.
- 29 Packing not suitable for operating conditions.
- 30 Shaft sleeve worn in the region of the packing.
- 31 Bearing worn out.
- 32 Specified oil level not maintained.
- 33 Insufficient lubrication of bearings.
- 34 Ball bearings over-lubricated.
- 35 Oil/Grease quality unsuitable.
- 36 Ball bearing incorrectly fitted.
- 37 Axial stress on ball bearings (no axial clearance for rotor).
- 38 Bearings dirty.
- 39 Bearing rusty (corroded).
- 40 Axial thrust too great because of worn casing rings, relief holes obstructed.
- 41 Insufficient cooling water supply to stuffing box cooling.
- 42 Sediment in the cooling water chamber of stuffing box cooling.
- 43 Alignment for coupling faulty or coupling loose.
- 44 Elastic element of coupling worn.
- 45 Pump casing under stress.
- 46 Pipeline under stress.
- 47 Shaft runs untrue.
- 48 Shaft bent.
- 49 Rotor parts insufficiently balance
- 50 Rotor parts touching the casing.
- 51 Vibration of pipe work.
- 52 Non-return valve gets caught.
- 53 Contaminated delivery liquid.
- 54 Obstruction in delivery line.
- 55 Delivery flow too great.
- 56 Pump unsuitable for parallel operation.
- 57 Type of pump unsuitable.
- 58 Incorrect choice of pump for existing operating conditions.
- 59 Voltage too low/ power supply overloaded.
- 60 Short circuit in the motor.
- 61 Setting of starter of motor too high.
- 62 Temperature of delivery liquid too high.



## REPLACEMENT DETAILS

Name of Part	Date of Replacement	Reason for Replacement	Serviced by	Remarks
Impeller				
Pump Shaft				
Shaft Sleeve				
Casing Rings				
Bearings				
Stuffing Box Bush/Mech. Seal				
Other parts				