

## AC SOLENOID & SOLENOID BRAKES



**BCH ELECTRIC LIMITED**  
*we care for you*



# Solenoid Brakes

BCH AC Solenoid operated brakes type 'S' are designed for long life, easy installation and minimum maintenance. They are electrically released and spring applied providing 'Fail-safe' operation. The retarding torque developed is directly proportional to the spring pressure.

The brake wheel is of relatively large size in relation to the torque developed by the brake. This permits use of a large brake shoe lining and lower shoe pressure. Low shoe pressure, equally distributed over a large lining area, results in even wear of the friction surfaces and even braking torque. The over-size wheel type construction also permits use of a smaller operating solenoid that requires less current for a given torque rating.

Low shoe pressure reduces the stress on all pins and pivot points to extend mechanical life and reduce maintenance costs. There is no unbalance of forces to cause side thrust during braking, because shoe type brake does not depend upon a wrapping action of the lining around the wheel.

## Applications

Typical applications include conveyors, hoisting, equipment, machine tools, printing presses, small cranes, over head doors, vacuum moulding machines etc.

## Constructional features

Special constructional features such as those listed below account for exceptionally long mechanical life of the brakes.

- (i) Neoprene shock absorber—prevents link pin breakage and increases the life of the solenoid.
- (ii) Hardened steel lever and spring gland—the hardened steel construction of the lever and spring gland reduces wear at the pins and all other points of contact.
- (iii) Cast iron wheel—The physical properties of the iron minimise the tendency of the wheel to deposit metal particles in the lining which could result in serious scoring of the wheel.
- (iv) Spring pins—The tight gripping spring pins insure against the loss of pins due to shock.
- (v) Inexpensive lining replacement—Linings attached to shoes by removable flat head groove-pins.
- (vi) Fewer joints—The shoe is actually a part of the shoe lever and not separate from it. This makes for fewer mechanical joints and keeps wear points at a minimum.
- (vii) Solenoid—The solenoid coil can be removed without disturbing the brake adjustment. Solenoid loading is designed to reduce wear.

## Adjustments

Adjustments for torque and lining wear are conveniently and quickly made. Braking torque and lining wear adjustments are made at the top of the brake. A set screw and locking nut located on the top of the solenoid frame provide adjustment for equalising clearance between the brake shoes to prevent dragging when the brake is released.

## Coil duty classification

Shunt brake coils are rated either for intermittent (1 hour) duty, or continuous duty. Intermittent duty indicates that the coil can be placed across the line for one hour without excessive heating. This is equivalent to 1/2 time duty or one minute on and one minute off. Coils rated for continuous duty can be connected across the line continuously without exceeding temperature limits.

The class of insulation of coils is class F.

## Mounting

Type 'S' brakes are designed and recommended for use and mounting only in the floor position. Side or vertical mountings are not recommended because the solenoid loading is altered resulting in accelerated and premature coil failure.

## Brake selection

The method most generally used to determine the required braking torque is to calculate the full load motor torque by means of the following formula :

$$T = \frac{9552 \times kW}{n}$$

- T = Full load motor torque in Newton Metre (Nm)  
kW = Motor output in kilowatts  
n = Rated speed of the motor shaft on which brake wheel is mounted in revolution per minute (r.p.m.)

The torque rating of brake selected should be at least equal to the full load motor torque for the duty considered.

In some applications where the brake must stop or hold abnormal loads on the driving equipment, the braking torque must be determined using the extreme operating conditions. In these cases, the braking torque is determined by calculating the maximum load and



translating it into torque at the shaft on which the brake is mounted.

Because of the large lining area, the capacity of Type 'S' brakes is generally considered ample for average application. However when brakes are to be used for frequent stopping or for stopping heavy inertial loads requiring long periods of deceleration.

Complete details, including  $Wk^2$ , speed of load referred to brake shaft and frequency of stops should be referred to the factory for analysis.

## Brake selection chart

Brake Type	Wheel dia mm approx.*	Max. torque N.m	Moment of Inertia $Wk^2$ (kgm <sup>2</sup> )	Coil duty
S-42	100	13.6	0.004	Continuous or Intermittent
S-51	140	34.0	0.018	Continuous or Intermittent
S-52	140	48.0	0.018	Intermittent
S-71	180	68.0	0.066	Continuous or Intermittent
S-72	180	102.0	0.066	Intermittent

- \*(i) Approximate value of wheel diameter has been specified in view of rounding off the values as basically the wheel diameter is in inches. For exact dimensions, please refer to the dimensional drawing of the wheel.
- (ii) Wheel is supplied as an accessory to the brake.
- (iii) Wheels will be supplied having straight pilot bore of minimum size to be machined further upto maximum bore range by the customer.

## Coil data

Class of insulation : Class F

Duty : Continuous or Intermittent

Brake Type	Coil Colour	Inrush Volt Amp	Inrush Watts	Sealed Volt Amp	Sealed MaxWatts
S-42	Red	465	310	90	20
S-51	Dark brown	2200	1300	250	70
S-52	Black	2350	1300	290	100
S-71	Dark brown	2200	1300	250	70
S-72	Black	2350	1300	290	100

## Dimensions (mm)

Type	Brake Size	Torque Rating N.m.																	
S-42	101.6	13.6	73.2	177.8	66.6	31.8	139.7	77.7	9.8	16.0	73.2	6.4	69.9	41.2	41.2	-	76.2	79.3	44.5
S51/S52	139.7	34.0/48.0	101.6	239.8	88.9	50.8	212.9	104.6	11.1	25.4	124.0	9.7	82.6	50.8	50.8	79.3	95.3	79.3	-
S71/S72	177.8	68.0/102.0	127.0	290.6	111.3	63.5	241.3	127.0	14.3	25.4	152.4	-	108.0	53.9	76.2	79.3	120.7	79.3	-
	A		B	C	D	E	F	G	H	J	K	L	M	N	O	P	Q	R	S

Catalogue code : Product code-Type-Coil voltage code

Brake : Product code : S

Type 42	-	Corresponding	Torque 13.6	Nm
Type 51	-	Corresponding	Torque 34	Nm
Type 52	-	Corresponding	Torque 48	Nm
Type 71	-	Corresponding	Torque 68	Nm
Type 72	-	Corresponding	Torque 102	Nm
Voltage code.	A	- 110V 50 Hz		
	B	- 220V		
	L	- 380V		
	M	- 415V		
	C	- 440V		

(Please write voltage/frequency in place of voltage code for non-standard voltage/frequency)

A solenoid brake with torque rating of 13.6 Nm operating at 380V 50 Hz will be termed as S42L.

## Accessories

### Wheel (Drum)

Wheel dia	Catalogue code
4" 100 mm	AC 50 D4
5.5" 140 mm	AC 50 D5
7" 180 mm	AC 50 D7

### Spares

Description	Catalogue code		
Brake type	S-42	S-51/S-52	S-71/S-72
Brake lining	SP50L1	SP50L2	SP50L3
Brake coil* (Continuous duty)	SP50MC01*	SP50MC21*	SP50MC21*
Brake coil* (Intermittent duty)		SP50MC22*	SP50MC22*
Brake magnet Assembly (Without coil)	SP50MA4	SP50MA5	SP50MA7
Brake Shoe Assembly with lining	SP50SA1	SP50SA2	SP50SA3

\* For brake coil, suffix coil voltage code from brake code column.

### Weight (kgs)

Type	Brake only	Net brake with wheel	Net wheel only
S-42	5.6	7.2	1.6
S-51/S-52	11.7	15.1	3.4
S-71/S-72	15.3	23.9	8.6

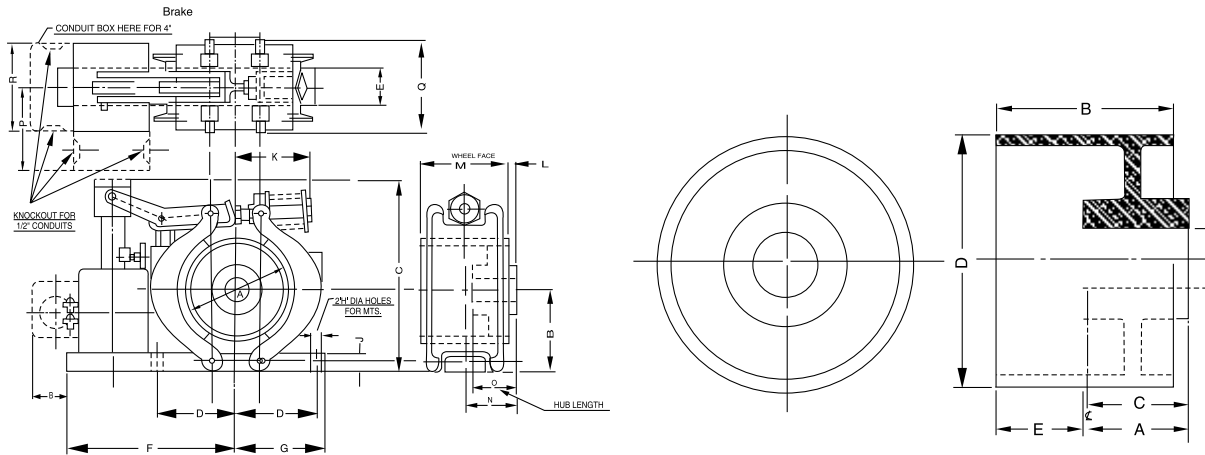

Drum Size approx	A	B	C	D	Bore			
					Min	Max	E	
100	41	70	41	101.6	+0.00 -0.10	12.7	34.92	34.92
140	51	82	51	139.7	+0.00 -0.10	19.0	50.8	41.27
180	76	108	54	177.8	+0.00 -0.18	19.0	57.15	31.75

## AC Solenoids

The remarkable efficiency of Bhartia Industries Limited's AC Solenoids (Pull Type) encourages application to a wide range of purposes requiring a definite pull motion under automatic or distant control in connection with electrically driven machinery.

Typical functions include the operation of electromechanical brakes and valves, various short-stroke motions on machine tools and many operations required in automatic machinery of all kinds.



## Specifications

The solenoid consists of laminated frame and plunger with steel supporting frame. The epoxy moulded coil is held in place by means of flat steel springs to prevent transmission of shock to the coil. The plunger and frame are carefully machined to ensure quiet operations. Solenoids can be used for up to 600 operations per hour if the pull-in time is within specified limits. These solenoids are provided with fixing holes for floor mounting.

## Electrical and mechanical ratings

Solenoid type Duty		Size B	Size D
		Continuous or intermittent	Continuous or intermittent
Maximum stroke length (mm)		25	31.4
Pull at rated voltage (Gross)*	kg	1.25	6.75
Pull at 85% of rated voltage (Gross)*	kg	0.9	4.5
Weight of plunger	kg	0.2	0.3
Operating time	m sec	70	70
Coil consumption (sealed)	VA	90	220
Coil consumption (in rush)	VA	465	1790
Weight	kg	1.2	2.9

Standard coil voltage offered : 110, 220, 380, 415, 440V 50Hz

\* When the solenoid is working against gravity, the weight of the plunger must be subtracted in order to ascertain the effective pull. When working with gravity, the weight of the plunger must be added.

## Catalogue code

Product code	SL
Solenoid size	B or D
	380V-L, 415V-M

eg. SLBL represents Solenoid size B with 380V coil



## Dimensions (mm)

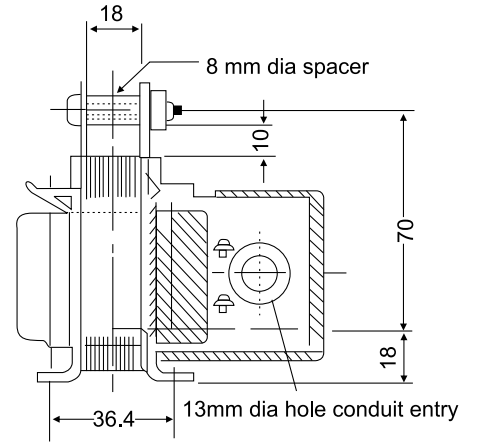
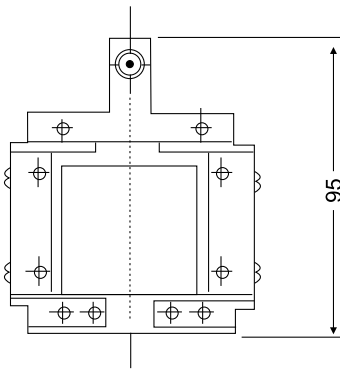
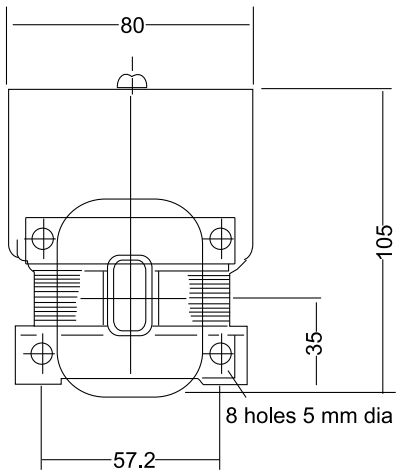

Solenoid Size B

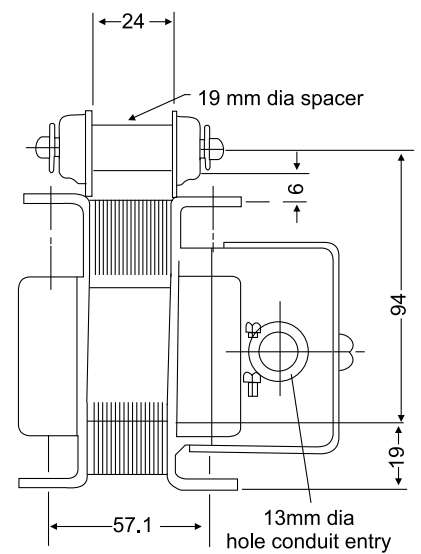
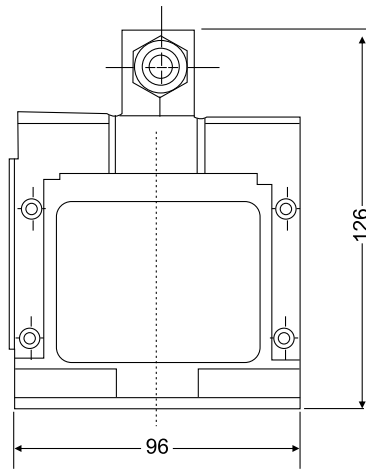
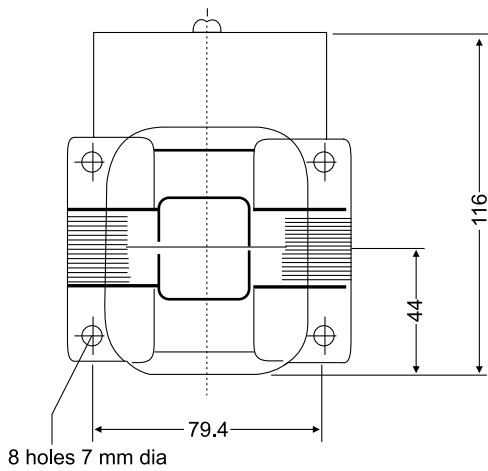

Solenoid Size D