

- Switchgear & Controlgear
- Automation
- Enclosures
- Electric Motors
- Wires & Cables
- Reactive Power Management
- Brakes and Crane Control
- Custom Built Products

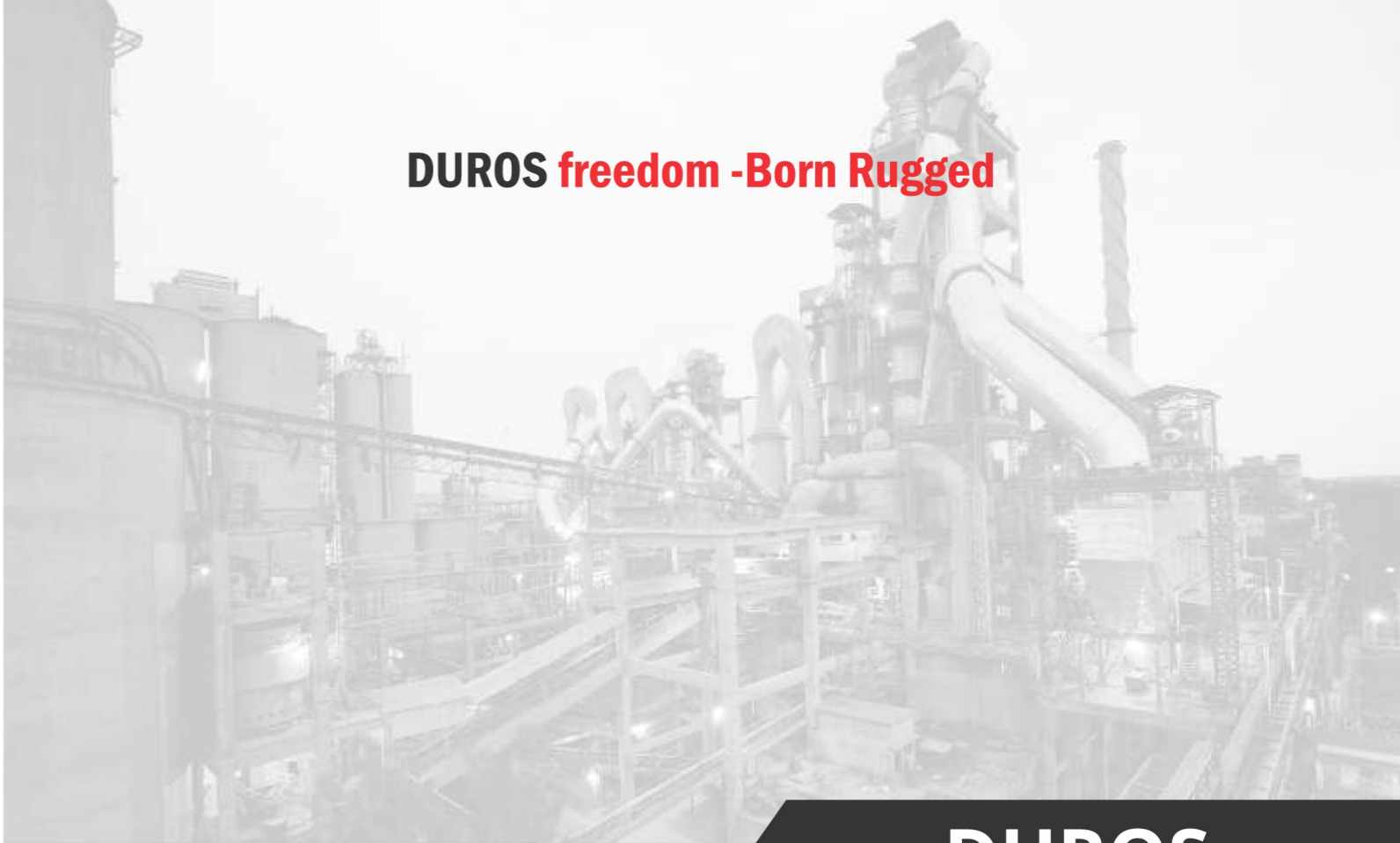

**DUROS freedom -Born Rugged**



**Contactors & Overload Relays**

**DUROS**  
Freedom Series



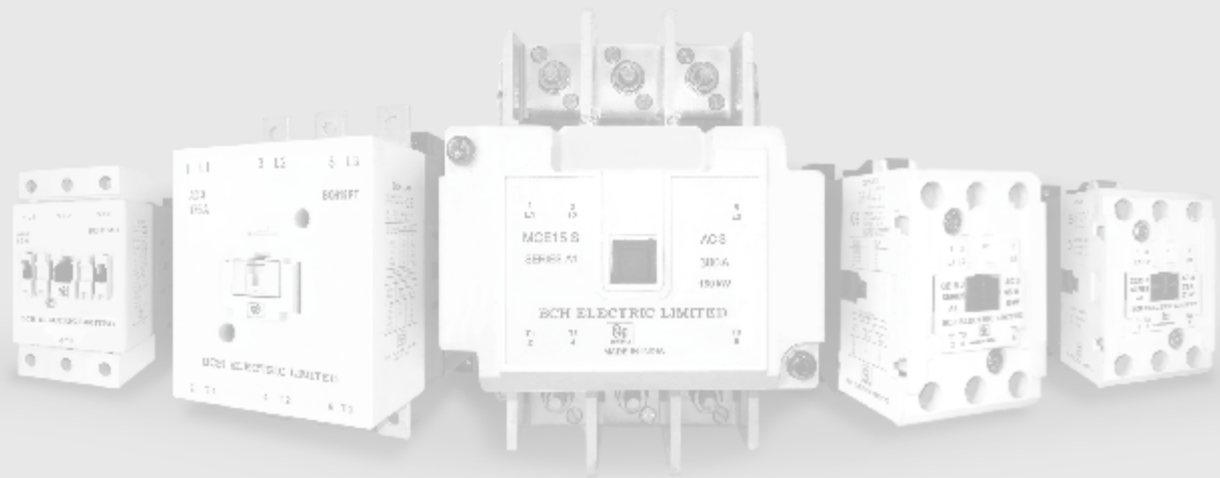

# **BCH DUROS** Freedom Contactors

Ever Wondered...

Having a contactor which can perform efficiently in spite of the Harshesht & Toughest environmental conditions?

Having a contactor which can last a life time?

Having a contactor which can save more energy?

Having a contactor which can fit into your smallest space available?

## INDEX

**DUROS**  
Freedom Series

CONTACTOR SPECIFICATIONS

1 - 3

CONTROL CONTACTOR & OVERLOAD RELAYS

4 - 6

ORDERING INFORMATION

6

ADD-ON ACCESSORIES

7

MECHANICAL DIMENSIONS & CHARACTERISTIC CURVES

8 - 12

INDUSTRIES & APPLICATIONS

13

ABOUT BCH

14

**BORN RUGGED**

## UNMATCHED PERFORMANCE IN TOUGH ENVIRONMENTS

# DUROS

Freedom Series

- Highly reliable operation
- No deration up to 60° C (AC3 duty)
- Time tested for heavy duty applications for 2 decades



## LASTS A LIFE TIME

- Rugged construction
- Electrical life as high as 2.7 Million
- Mechanical life as high as 20 Million
- Insulation Voltage as high as 1 kV
- Impluse voltage as high as 8 kV

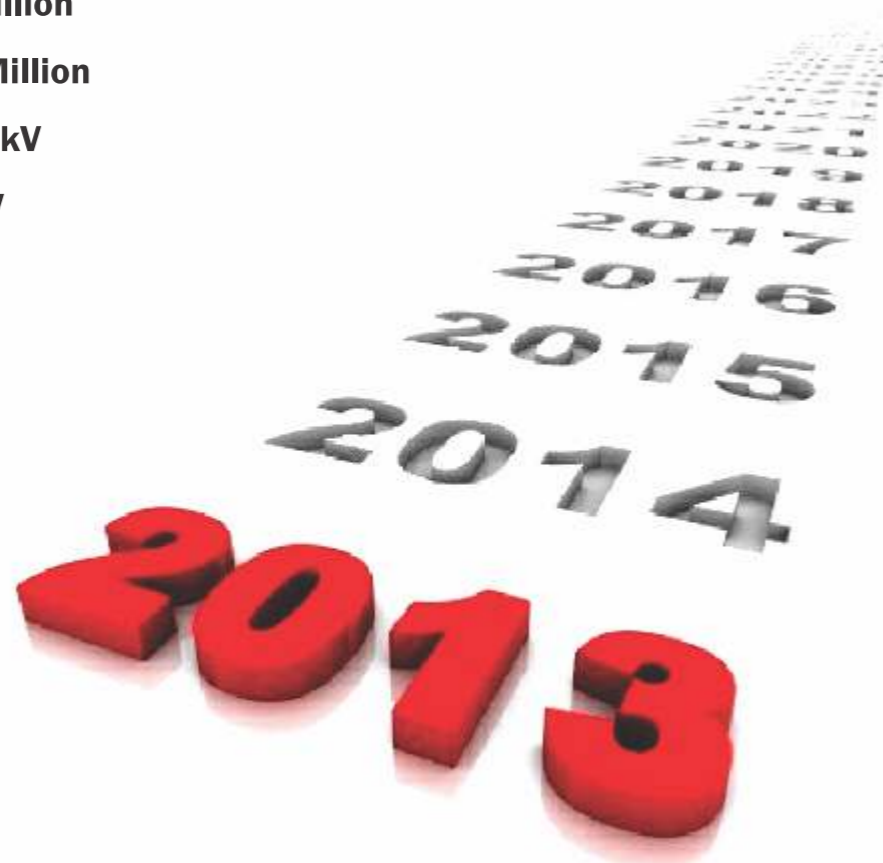

## ENERGY EFFICIENCY - THE GREENEST CONTACTOR

# DUROS

Freedom Series

- Lower VA burdens (as low as 5 VA)
- Clean Pick-up
- Sophisticated Electronic control



## MOST COMPACT DESIGN

- Most compact construction
- Higher ratings in lower frame sizes
  - 110A contactor in 79mm frame
  - 175A contactor in 110mm frame



**CONTACTOR GENERAL CHARACTERISTICS Standard - IS/IEC 60947-4-1**
**CONTACTOR GENERAL CHARACTERISTICS Standard - IS/IEC 60947-4-1**

Operating Temperature : -20°C to +60°C  
 Operating Altitude : 2000m  
 Humidity : 50% RH at 60°C  
 : 95% RH at 40°C  
 Vibration : 5 to 100 Hz (0.7g in x,y,z plane)  
 Operating position : ±30°



Operating Temperature : -20°C to +60°C  
 Operating Altitude : 2000m  
 Humidity : 50% RH at 60°C  
 : 95% RH at 40°C  
 Vibration : 5 to 100 Hz (0.7g in x,y,z plane)  
 Operating position : ±30°



CONTACTOR CAT. REFERENCE		CE15AN -3=B	CE15BN -3=B	CE15CN -3=B	CE15DN 3=B	CE15EN 3=B	CE15FN 3=B	CE15GN 3=B	CE15HN 3=B	CE15JN 3=B	CE15KN 3=B	CONTACTOR CAT. REFERENCE		BCH15KT -3-11-■	BCH15LT -3-11-■	BCH15MT -3-11-■	BCH15NT -3-11-■	BCH15PT -3-11-■	MCE15RN 3=7	MCE15SON 3=7	MCE15SN 3=7			
Nominal current rating at 380/415V 50Hz (AC3 Duty)	Ie (A)	6	9	12	18	25	32	40	50	65	75	Nominal current rating at 380/415V 50Hz (AC3 Duty)	Ie (A)	80	95	110	150	175	200	265	300			
Standard power rating at 380V / 415V 50Hz	P (kW)	2.2/2.2	4/4	5.5/5.5	9.0/9.0	11/11	15/15	18.5/22	22/25	30/37	37/37	Standard power rating at 380V / 415V 50Hz	P (kW)	37 / 40	45 / 47	55 / 59	75 / 80	90 / 95	110/110	90/90	160/160			
Electrical endurance at rated current AC3 Duty	Million	2.7	2.3	2.1	1.5	1.5	1.7	1.1	1.3	1.4	1.3	Electrical endurance at rated current AC3 Duty	Million	0.8	0.8	0.8	0.8	0.8	0.52	0.55	0.351			
Maximum frequency of no load operation	op/h	600	600	600	600	600	600	600	600	600	600	Maximum frequency of no load operation	op/h	3000			1200			600	600	300		
<b>MECHANICAL DATA</b>												<b>MECHANICAL DATA</b>												
Frame size	mm	45						65				Frame size	mm	79			110			178				
Number of poles		4	4	4	3	3	3	3	3	3	3	Number of poles	3	3	3	3	3	3	3	3	3			
Mounting Dimensions	mm	M4 34.5x60						M5 55x95				Mounting Dimensions	mm	M5 70x100			M5 100x130			M6 160x166.5				
Weight	Kg	0.41	0.41	0.41	0.44	0.44	0.44	1.28	1.28	1.28	1.28	Weight	Kg	1.8		2	4		8.3					
Mechanical durability	Million	20	20	20	20	20	20	10	10	10	10	Mechanical durability	Million	10			5							
<b>POWER CIRCUIT</b>												<b>POWER CIRCUIT</b>												
Operational voltage	Ue (V)	660	660	660	660	660	660	660	660	660	660	Operational voltage	Ue (V)	1000			660							
Insulation voltage	Ui (V)	690	690	690	690	690	690	690	690	690	690	Insulation voltage	Ui (V)	1000			690							
Impulse Voltage withstand	kV	6	6	6	6	6	6	6	6	6	6	Impulse Voltage withstand	kV	8	8	8	8	8	6	6	6			
Thermal current	Ith (A)	20	20	20	32	40	40	60	75	80	80	Thermal current	Ith (A)	125		135	230	250	300	315	315			
Connections	mm <sup>2</sup>	2.5	2.5	2.5	6	6	6	25	25	25	25	Connections	mm <sup>2</sup>	50			120			240				
AC-1 Duty rated at 380/415V 50Hz	Ie (A)	20	20	20	32	40	40	60	75	80	80	AC-1 Duty rated at 380/415V 50Hz	Ie (A)	125		135	230	250	300	315	315			
AC-4 Duty rated at 380/415V 50Hz	Ie (A)	6	9.1	12	16	23	23	37	44	50	59	AC-4 Duty rated at 380/415V 50Hz	Ie (A)	80	90	110	150	175	140	165	170			
Electrical life at rated current AC4 Duty	ops.	60000	59000	43000	67000	52000	75000	58000	62000	35000	34000	Electrical life at rated current AC4 Duty	ops.	20000			65000			60000	60000			
AC-4 Duty rating for 200000 operations	Ie (A)	2.5	4.3	4.8	8.3	10	12	17	34	34	34	AC-4 Duty rating for 200000 operations	Ie (A)	27	31	34	41	50	70	75	80			
Stator current rating acc. to AC2 Duty (A) ≤55°C	100% DF	6	9	12	16	25	32	40	50	65	73	Stator current rating acc. to AC2 Duty (A) ≤55°C	100% DF	80	95	110	150	175	200	265	300			
Rotor Duty rating-Delta Connected (A) ≤40°C	100% DF	12	16	21	29	40	52	64	76	104	126	Rotor Duty rating-Delta Connected (A) ≤40°C	100% DF	160	175	224	280	350	393	425	465			
	60% DF	15	21	27	38	51	67	83	98	134	163		60% DF	185	200	250	325	406	507	550	600			
	40% DF	19	26	33	47	63	82	101	120	164	200		40% DF	217	236	245	380	475	621	700	735			
	20% DF	27	36	46	66	89	116	143	170	232	283		20% DF	272	296	360	475	594	879	950	1040			
Maximum Rotor Voltage - Starting & Inching Starting & Plugging		Delta connected - 1160V ; Star connected - 1380V Delta connected - 580V ; Star connected - 690V										Maximum Rotor Voltage - Starting & Inching Starting & Plugging		Delta connected - 1160V ; Star connected - 1380V Delta connected - 580V ; Star connected - 690V										
Transformer primary switching 500V AC	A	3.1	4.2	5.4	7.6	10	13	15	20	20	24	Transformer primary switching 500V AC	A	36	40	50	65	80	90	100	135			
Capacitor switching(single bank only) 380/400V, 3ph	kVAR	4.9	6.7	8.6	12	15	15	25	30	37	40	Capacitor switching(single bank only) 380/400V, 3ph	kVAR	40	50	60	80	100	110	140	158			
<b>CONTROL CIRCUIT</b>												<b>CONTROL CIRCUIT</b>												
Coil VA Consumption	Pickup VA	70				92				230				Coil VA Consumption	Pickup VA	250			350			1040		
	Seal VA	6.4				8				28					Seal VA	18			5			116		

■ Suffix code for Coil Voltage • Code for built-in Aux. Contact (S-1NO, C-1NC)

■ Suffix code for Coil Voltage

## CONTACTOR GENERAL CHARACTERISTICS Standard - IS/IEC 60947-4-1

Operating Temperature : -20°C to +60°C  
 Operating Altitude : 2000m  
 Humidity : 50% RH at 60°C  
 : 95% RH at 40°C  
 Vibration : 5 to 100 Hz (0.7g in x,y,z plane)  
 Operating position : ±30°



CONTACTOR CAT. REFERENCE		BCH54 3-22-■	BCH55 3-22-■	BCH57 3-22-■	BCH62 3-22-■	BCH64 3-22-■	BCH76 3-12-■	BCH78 3-12-■	
Nominal current rating at 380/415V 50Hz (AC3 Duty)	Ie (A)	400	450	550	700	860	1000	1200	
Standard power rating at 380V / 415V 50Hz	P (kW)	220/240	220/240	280/315	375/400	475/500	550/600	650/700	
Electrical endurance at rated current AC3 Duty	Million	0.6	0.6	0.6	0.6	0.6	0.6	0.6	
Maximum frequency of no load operation	op/h	300	300	300	300	300	120	120	
<b>MECHANICAL DATA</b>									
Frame size	mm	220			280		334		
Number of poles		3	3	3	3	3	3	3	
Mounting Dimensions	mm	M8 110x220			M10 175x280		M12 120x380		
Weight	Kg	13.0	13.0	13.5	26.4	27.6	49	53	
Mechanical durability	Million	5	5	5-10	5-10	5-10	1-5	1-5	
<b>POWER CIRCUIT</b>									
Operational voltage	Ue (V)	1000	1000	1000	1000	1000	690	690	
Insulation voltage	Ui (V)	1000	1000	1000	1000	1000	690	690	
Impulse Voltage withstand	kV	8	8	8	8	8	8	8	
Thermal current	Ith (A)	600	600	760	1000	1100	1200	1350	
Connections	mm <sup>2</sup>	2(40x5)	2(40x5)	2(50x5)	2(60x5)	2(60x6)	2(60x6)	2(60x6)	
AC-1 Duty rated at 380/415V 50Hz	Ie (A)	600	600	760	1000	1100	1200	1350	
AC-4 Duty rated at 380/415V 50Hz	Ie (A)	400	450	550	700	860	1000	1200	
Electrical life at rated current AC4 Duty	ops.	6000	6000	6000	6000	6000	6000	6000	
AC-4 Duty rating for 200000 operations	Ie (A)	100	115	140	185	215	265	300	
Stator current rating acc. to AC2 Duty (A) ≤55°C	100% DF	400	450	550	700	860	1000	1200	
Rotor Duty rating-Delta Connected (A) ≤40°C	100% DF	750	840	1060	1400	1540	1680	1850	
	60% DF	860	960	1210	1600	1760	1930	2120	
	40% DF	1020	1130	1430	1890	2080	2270	2500	
	20% DF	1300	1420	1790	2370	2610	2840	3130	
Maximum Rotor Voltage - Starting & Inching Starting & Plugging		Delta connected - 1700V ; Star connected - 2000V Delta connected - 850V ; Star connected - 1000V					Delta connected - 1160V ; Star connected - 1380V Delta connected - 580V ; Star connected - 690V		
Transformer primary switching 500V AC	A	185	203	250	315	390	450	540	
Capacitor switching(single bank only) 380/400V, 3ph	kVAR	190	200	250	350	400	450	500	
<b>CONTROL CIRCUIT</b>									
Coil VA Consumption	Pickup	VA	950			1600		2450	
	Seal	VA	11			25		75	

■ Suffix code for Coil Voltage

## CONTROL CONTACTOR & OVERLOAD RELAYS

### CONTROL CONTACTOR

Control Relay	D15CR22■, D15CR31■, D15CR40■		
Standards	IEC 60947-1, 60947-5		
Width (mm)	45		
Number of Poles	4		
Protection against Direct Contact	IP20		
Mechanical Life Span	20 Million		
Weight	410 gm		
Environment Pollution Degree IEC 60947-4-1	3		
Impulse Withstand Voltage IEC 60947-1	6kV		
Operating Temp. (open)	-20 to + 65°C		
Operating Altitude	2000m		
Operating Position (Related to normal mounting position)	±30°		
Contact Rating (rated thermal current, open I <sub>n</sub> )	10A		
Rated Insulation Voltage U <sub>i</sub>	690V		
Operating Frequency Limits	50 to 60Hz		
<b>AC 15 Duty</b>	<b>U<sub>e</sub></b>	<b>VA</b>	<b>I<sub>e</sub></b>
Control of AC	48	480	10
Electromagnetic Loads (Greater than 72VA)	120	720	6
	240	960	4
	440	880	2
	660	990	1.5
<b>DC 13 Duty</b>	<b>U<sub>e</sub></b>	<b>W</b>	<b>I<sub>e</sub></b>
Control of DC	24	192	8
Electromagnets	48	288	6
	120	120	1
	220	110	0.5
	440	110	0.25
	660	66	0.1
Coil Data	refer CE15BN • 3■		



### THERMAL OVERLOAD RELAYS

THERMAL OVERLOAD RELAYS		MC318ANA* / MC318GNA*	CT*MC305ANA3C	MC305ANA3*
Storage temperature	deg C.	-40 -- +70	-40 -- +60	-40 -- +60
Operating temperature	deg C.	-25 -- +55	-10 -- +55	-10 -- +55
Fixing		Direct/ Independent mounting	Independent mounting	Direct mounting
<b>POWER CIRCUIT</b>				
Rated Insulation Voltage U <sub>i</sub> (V)		690	690	690
Tripping Class as per IEC 947-4-1		10A	20	10
Switching Frequency Op./ Hr		15	15	15
<b>AUXILIARY CIRCUIT</b>				
Type of contacts		1NO+1NC	1C/0	1C/0
Reset type		Auto/ manual selectable	Auto/ manual selectable	Auto/ manual selectable
Rated voltage U <sub>i</sub> at NO/ NC contacts (V)		500	600	600
Rated operational current	240V (A)	3(NC)/ 1.5(NO)	2.5	2.5
	AC15 440V (A)	1.9(NC)/ 0.95(NO)	1.4	1.4
	500V (A)	1(NC)/ 0.75(NO)	1.2	1.2
I <sub>e</sub> DC13 220V (A)		0.12(NC)/ 0.04(NO)	0.12	0.12
Gg class protection fuse (A)		10(NC)/ 6(NO)	4	4

\* Please refer page no.5 for corresponding suffix.



## OVERLOAD RELAYS

### Citation Relay (Range: 0.195A to 600A)

- Built-in Single Phasing Protection
- Ambient Temperature Compensation
- Test button for checking tripping mechanism
- Field convertible auto/manual reset
- Snap on cover
- Contactor mounting & separate mounting for flexibility

### DUROS Freedom Relay (Range: 0.1A to 32A)

- Built-in Single Phasing Protection
- Ambient Temperature Compensation
- Test button for checking tripping mechanism
- Field convertible auto/manual reset
- Contactor mounting & separate mounting for flexibility

RELAY TYPE	Relay Range (A)	* Suffix for Corresponding range
 <b>CITATION DIRECT :</b> <b>MC305ANA3*</b>	0.195 to 0.31	A
	0.30 to 0.48	B
	0.47 to 0.75	C
	0.72 to 1.14	D
	1.07 to 1.70	E
	1.58 to 2.50	F
	2.40 to 3.80	G
	3.80 to 6.00	H
	6.00 to 9.30	J
	8.90 to 13.50	K
	13.20 to 20.00	L
	17.40 to 24.00	M
	22.00 to 30.00	N
 <b>CITATION - CT OPERATED :</b> <b>CT*MC305ANA3C</b>	24.40 to 39.00	1
	37.60 to 60.00	2
	56.40 to 90.00	3
	84.60 to 135.00	4
	131.60 to 210.00	5
	188.00 to 300.00	6
	263.20 to 420.00	7
	376.00 to 600.00	8

CITATION ACCESSORIES	CAT REFERENCE	RELAY TYPE
DIN Rail Kit	MC305DM1	For A - K Relay
	MC305DM2	For L - N Relay
Adjustment Cover	MC305PC	
Terminal Block*	MC305TB1	For Relay upto K Range
Terminal Block*	MC305TB2	For L, M & N Ranges
Terminal Block	MC305TB3	For Terminal Side (L, M & N Ranges)

\* Terminal Block are meant for converting contactor Mounting Relays to individual Mounting Relays. With N Relays use of Terminal Block MC305TB3 is essential.

## DUROS FREEDOM RELAY

RELAY TYPE	Relay Range (A)	* Suffix for Corresponding range
 <b>DUROS FREEDOM RELAY - DIRECT :</b> MC318ANA3*	0.10 to 0.16	A
	0.16 to 0.25	B
	0.25 to 0.40	C
	0.40 to 0.63	D
	0.63 to 1.00	E
	1.00 to 1.40	F
	1.30 to 1.80	G
	1.70 to 2.40	H
	2.20 to 3.10	J
	2.80 to 4.00	K
	3.50 to 5.00	L
	4.50 to 6.50	M
	6.00 to 8.50	N
	7.50 to 11.00	P
	10.00 to 14.00	Q
	13.00 to 19.00	R
18.00 to 25.00	S	
24.00 to 32.00	T	

### NOTES ON ORDERING INFORMATION

COIL VOLTAGE CODE FOR CONTACTORS	Coil Voltage AC	Suffix for AC	Suffix for DC*
COIL VOLTAGE CODE- SIZE D15CR, CE15AN, BCH15KT, BCH15LT, MCE15RN to SN	24	U	U3
	42	R	-
	48	W	W3
	110	A	A3
	220	B	B3
	240	K	-
	380	L	-
	415	M	-
	440	C	-
	550	D	-

\* DC coils are supplied upto size K/ 73A contactors

COIL VOLTAGE CODE FOR CONTACTORS	Coil Voltage AC	Suffix for AC	Suffix for DC*
BCH15MT, BCH15NT, BCH15PT	24	24	-
	110	110	-
	220/240	220	-
	380	380	-
	440	440	-
550	550	-	

COIL VOLTAGE CODE FOR CONTACTORS	Coil Voltage AC	Suffix for AC	Suffix for DC
BCH55 to BCH64	110	110	110
	220	220	220
	380	380	380
	440	440	440

COIL VOLTAGE CODE FOR CONTACTORS	Coil Voltage AC	Suffix for AC	Suffix for DC
BCH76, BCH78	48	-	W17
	110	A7	A17
	220	B7	B17
	380	L7	-
	440	-	-

■ Suffix code for Coil Voltage

## ADD-ON ACCESSORIES

### Additional Auxiliary Contact Blocks

Rated Thermal Current I <sub>th</sub>	10A
Rated Insulation Voltage	690V
Operating Frequency	50 - 60 Hz
AC15 Duty at 220/240V	960VA, 4A
DC 13 Duty at 220V	110W, 0.5A
Conditional Short Circuit Current	1kA



ACCESSORIES	CONFIGURATION	CAT NO.	CONTACTOR TYPE	
<p>Aux. Contact Block (side Mounting)</p>	1NO	C320KGSR10	CE15 & CR	
	1NO+1NC	C320KGSR11		
	1NC	C320KGSR01		
	2NO	C320KGSR20		
	<p>4th Neutral Switching Pole</p>	1NO+1NC	BCH15S11	BCH15
		1NO+1NC	MC320KB11	MCE15R to MCE15S
		2NO+2NC	EF22	BCH54 to BCH64
		1NO+1NC	EB11	BCH76 to BCH78
<p>Aux. Contact Block (Front Mounting)</p>		325A	NP325/5	BCH54 to 57
		500A	NP500/5	
		500A	NP500/6	
		900A	NP900/6	BCH62 to 64
	500A	NP500/7		
	900A	NP900/7		
<p>Pneumatic Timer Block "On/Off" Delay site selectable</p>	1NO	C320KGTC10	CE15, CR	
	1NC	C320KGTC01		
	2NO	C320KGT*20		
	2NC	C320KGT*02		
	<p>Mechanical Interlocks</p>	1NO+1NC	C320KGT*11	BCH15
		2NO+2NC	C320KGT*22	
		3NO+1NC	C320KGT*31	
		4NO	C320KGT*40	
		1NO+3NC	C320KGT*13	
		4NC	C320KGT*04	
		4NO	BCH15T40	
		3NO+1NC	BCH15T31	
	<p>Coil Surge Suppressors</p>	2NO+2NC	BCH15T22	
		1NO+1NC	BCH15T11	
1NO		BCH15T10		
1NC		BCH15T01		
<p>Mechanical Interlocks</p>	1NO+1NC (0.1 to 30 sec)	C320TP1	CE15, CR, BCH15	
	1NO+1NC (0.1 to 180 sec)	C320TP2		
	<p>Mechanical Interlocks</p>	-	C321KM60	CE15, CR
		-	MC321KM3	MCE15R to MCE15S
		H-Horizontal V-Vertical	BM5H / BM5V	BCH54 to 57
			BM6H / BM6V	BCH62 to 64
		H-Horizontal V-Vertical	BM7H / BM7V	BCH76 to 78
BM0H			BCH15	
BM3H				
<p>Coil Surge Suppressors</p>	24-48V (50/60Hz)	MC320LR11	CE15, CR	
	110-240V (50/60Hz)	MC320LR12		

\* Suffix code for Coil Voltage

## Contactor Dimension (mm)

### CE15BN TO FN

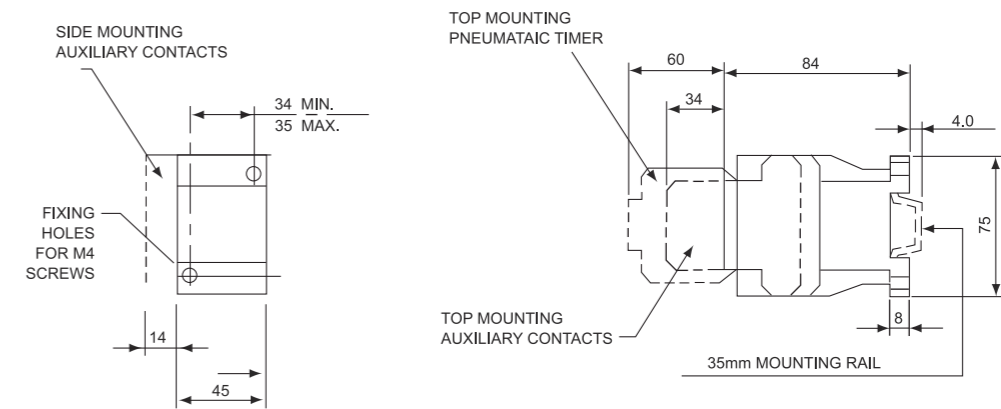

### CE15GN TO KN

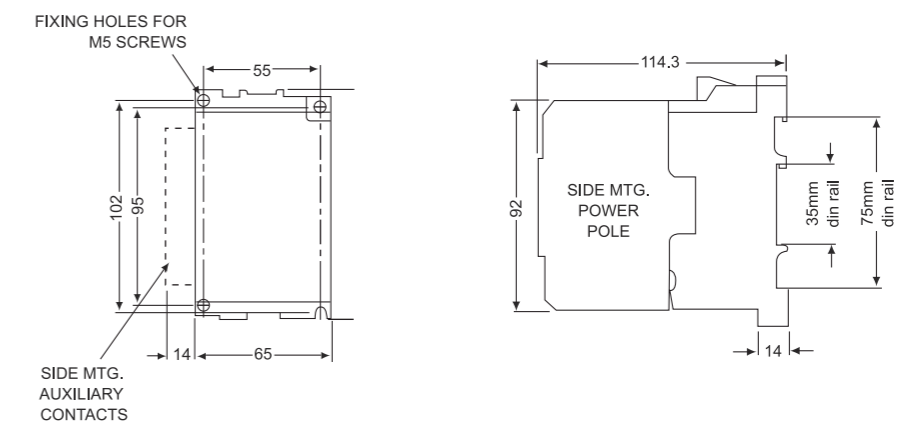

### CE15BN TO FN

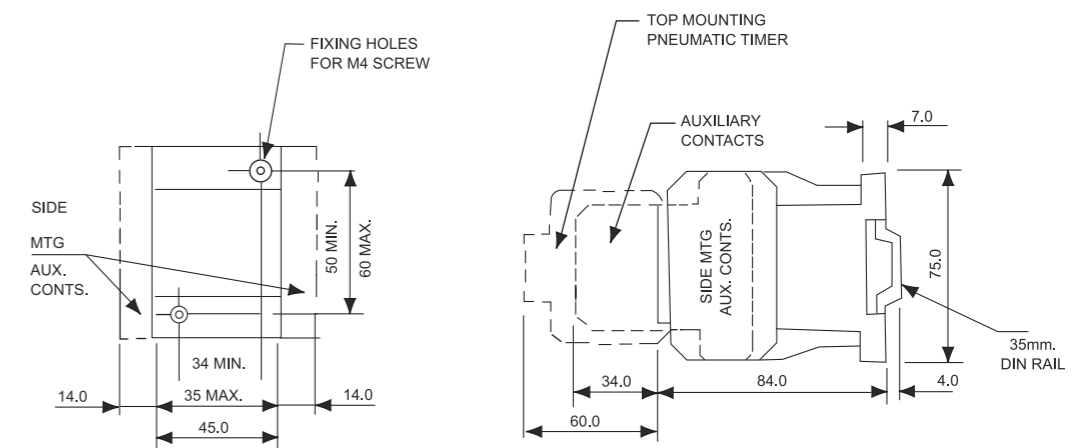

### CE15GN TO KN

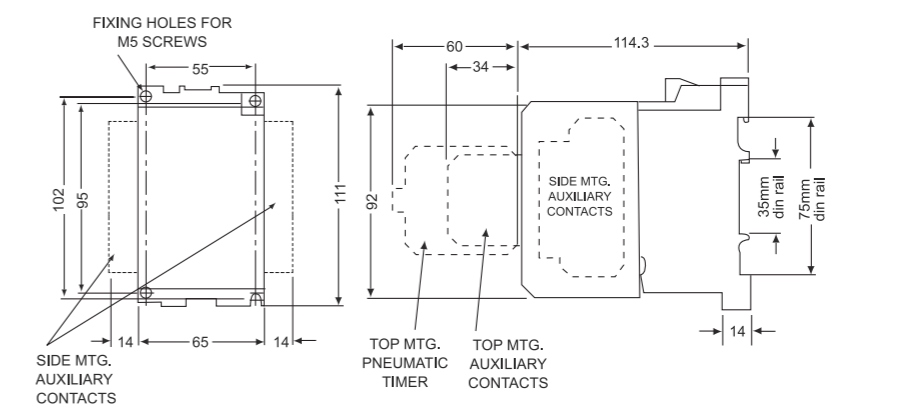

### Contactor Dimension (mm)

#### BCH15KT/LT

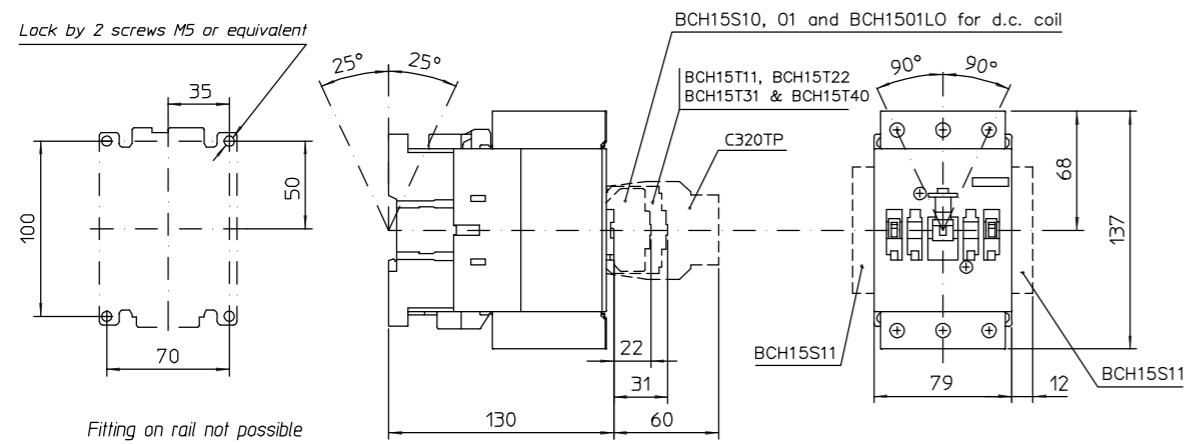

#### BCH15MT

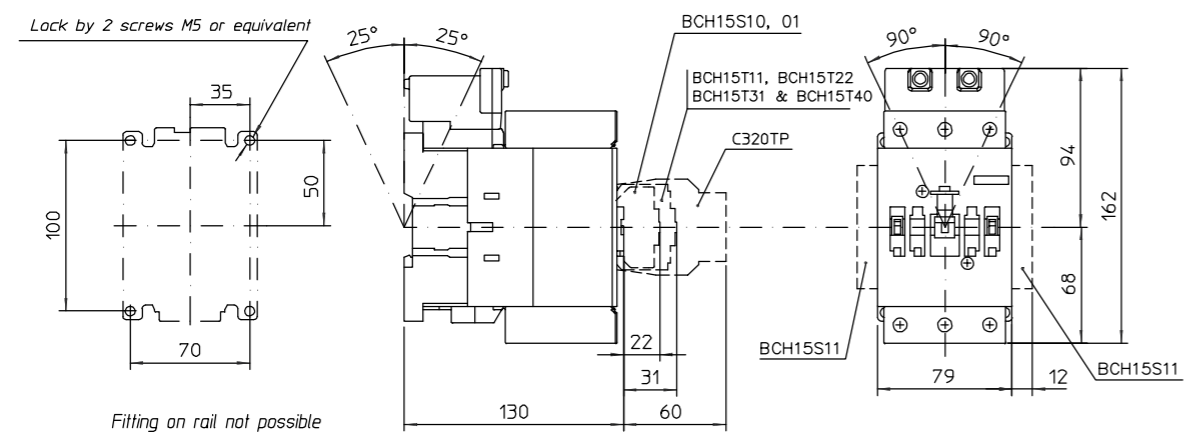

#### BCH15NT/PT

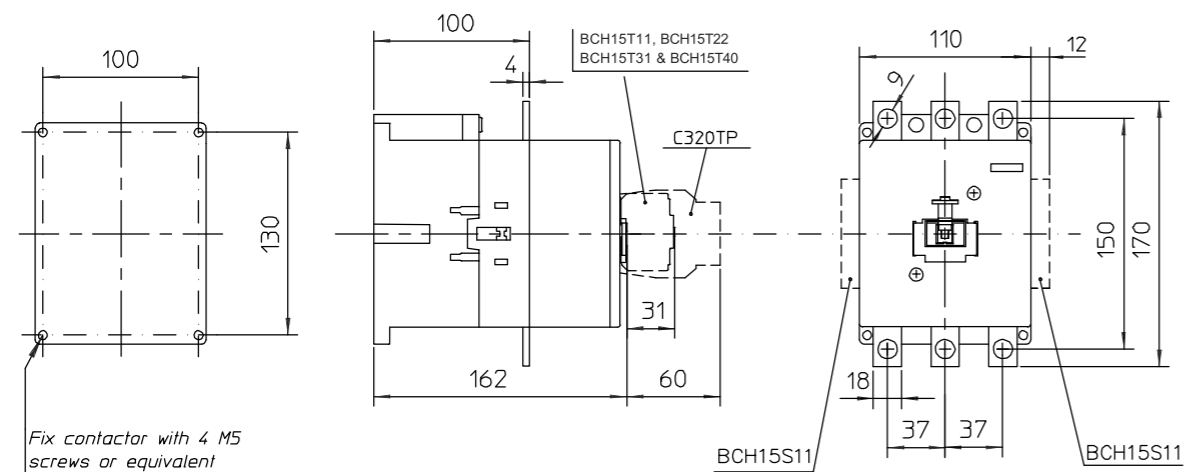

### Contactor Dimension (mm)

#### MCE15RN TO SN

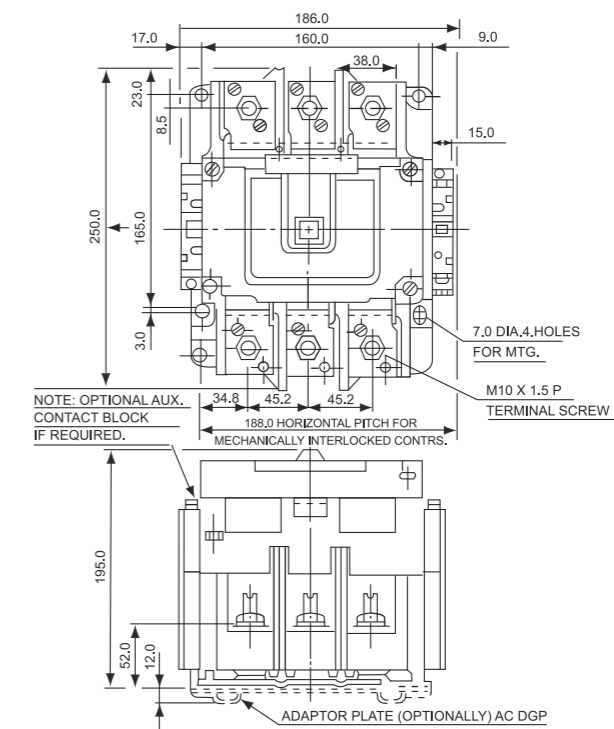

#### BCH54 TO BCH78

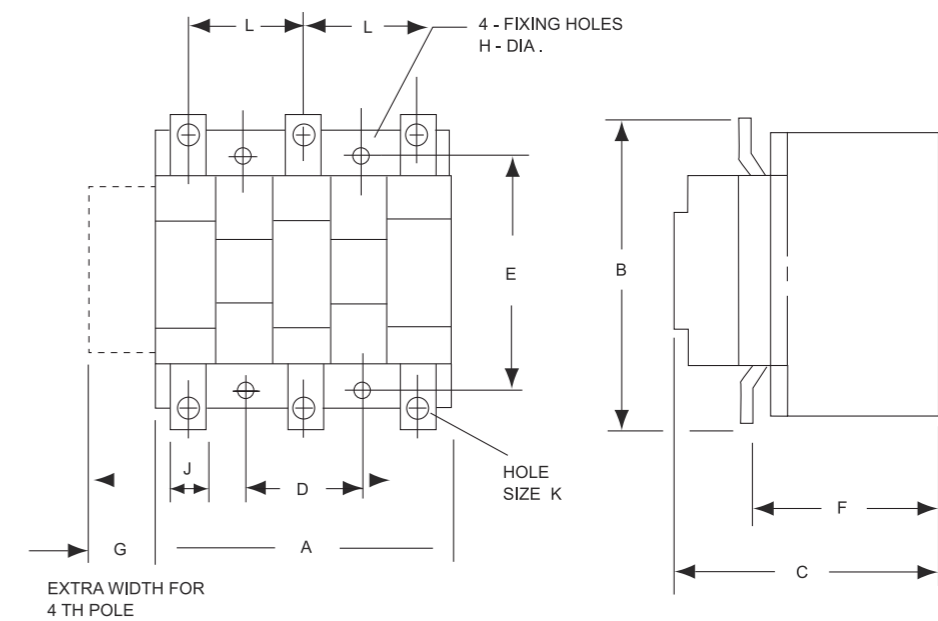

	A	B	C	D	E	F	G	H	J	K	L	Mechanical Interlock mounting matrix		Weight kg.
												Horiz.	Vert.	
BCH 54	220	233	225	110	220	160	72	8	30	10.5	80	262	314	13
BCH 55	220	233	225	110	220	160	72	8	30	10.5	80	262	314	13
BCH 57	220	258	225	110	220	160	72	8	40	12.5	80	262	314	13.5
BCH 62	280	307	291	175	280	200	90	10	50	13	100	312	380	26
BCH 64	280	361	291	175	280	200	90	10	50	15	100	312	380	28
BCH 76	334	490	345	120	380	220	111	12	50	17X2	100	380	580	49
BCH 78	334	490	345	120	380	220	111	12	60	17X2	100	380	580	53



## OVERLOAD RELAY - DIMENSIONS (mm)

### MC318ANA\* + C318 F1

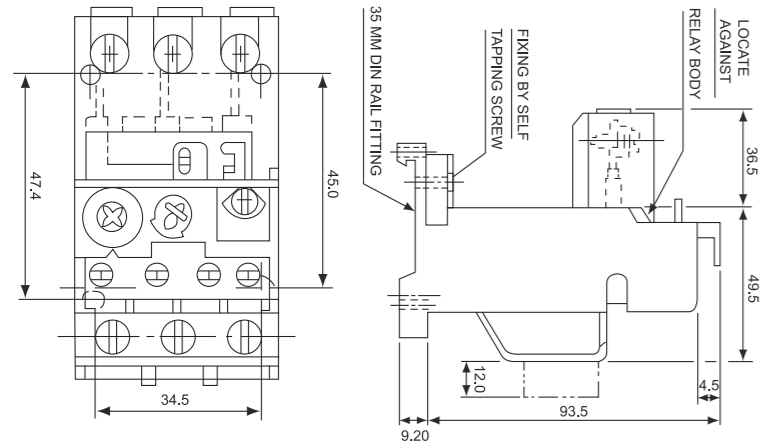

### CE15BN TO FN + MC318ANA 3\*

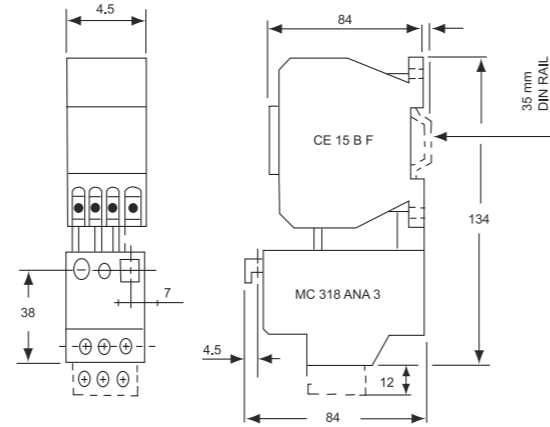

## OVERLOAD RELAY - DIMENSIONS (mm)

### CT2 - CT8

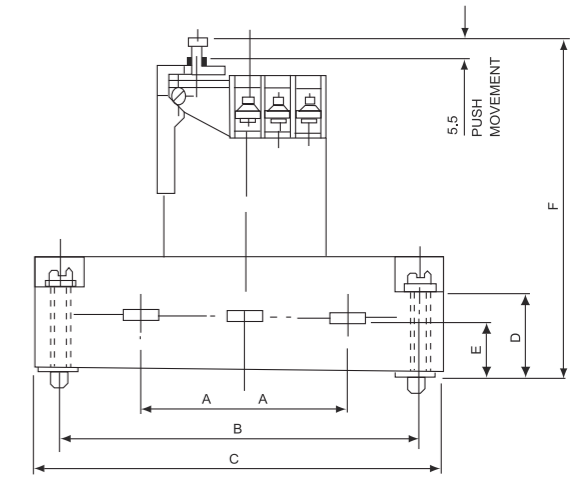
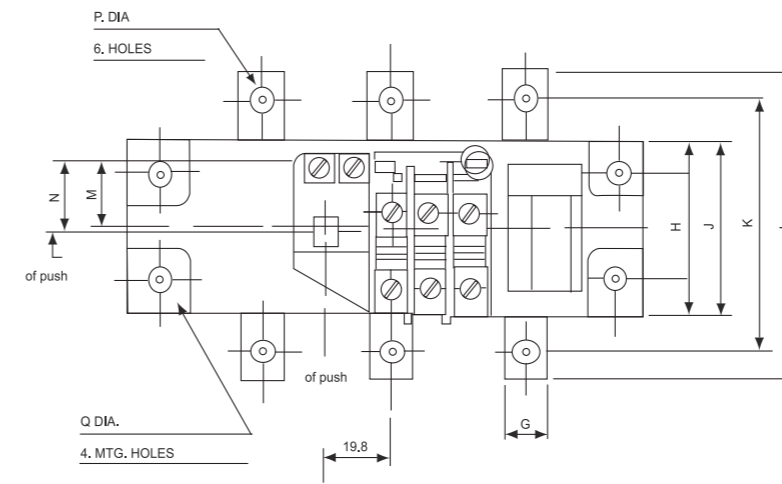

## CITATION - DIRECT READING RELAY

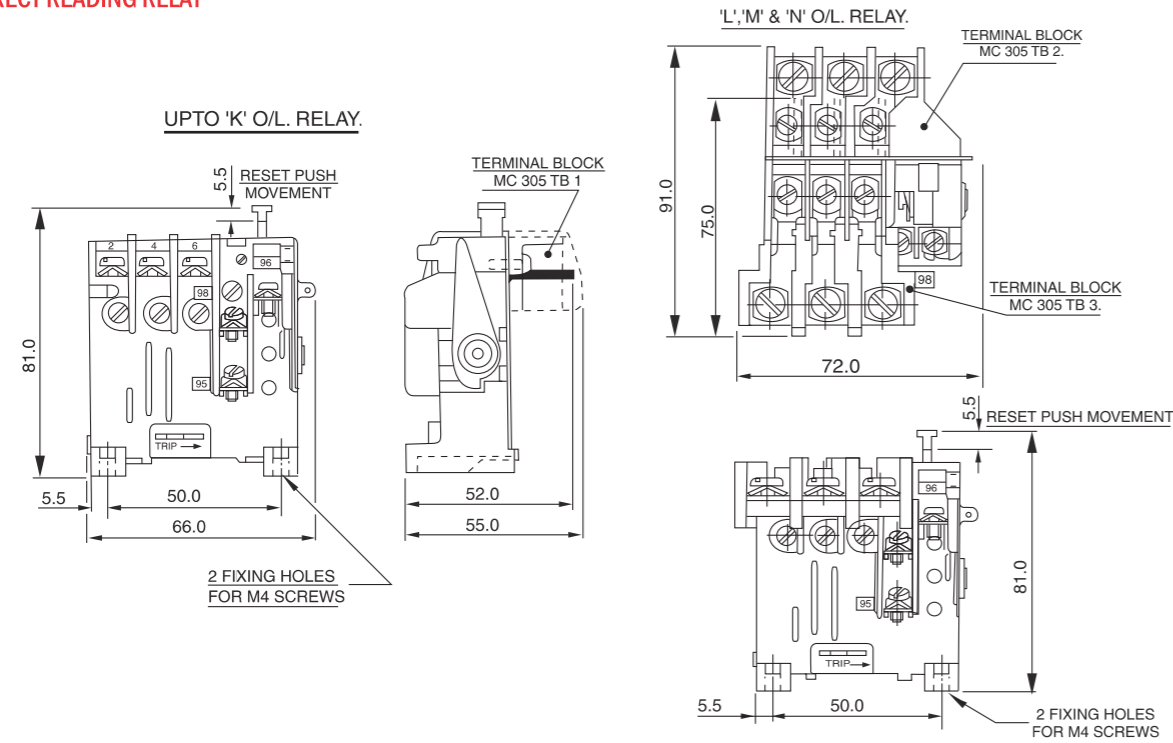

## CT OPERATED RELAY

Relay/type	A	B	C	D	E	F	G	H	J	K	L	M	N	P	Q
CT1	40	40	125	-	-	123	-	-	50	64	76	-	-	-	7.0
CT2	44	138	156	35	21.5	125	12	32	50	74	90	18.0	21.0	6.5	7.0
CT3	54	162	180	43	25.5	133	22	32	50	82	106	18.0	21.0	13.0	7.0
CT4	54	162	180	43	25.5	133	22	32	50	82	106	18.0	21.0	13.0	7.0
CT5	60	182	200	63	34.5	153	32	32	50	88	116	18.0	21.0	13.0	7.0
CT6	60	182	200	63	34.5	153	32	32	50	88	116	18.0	21.0	13.0	7.0
CT7	86	252	270	63	33.0	153	34	32	50	100	140	18.0	21.0	16.5	7.0
CT8	86	252	270	63	33.0	153	34	32	50	100	140	18.0	21.0	16.5	7.0

## WEIGHT (kg)

Citation M overload relay	: 0.123
Terminal block	: 0.029
C T operated relay	: CT1: 1.3
	CT2: 1.4
	CT3: 1.6
	CT5: 2.2
	CT6: 2.2
	CT7: 3.1
	CT8: 3.3

### CT1

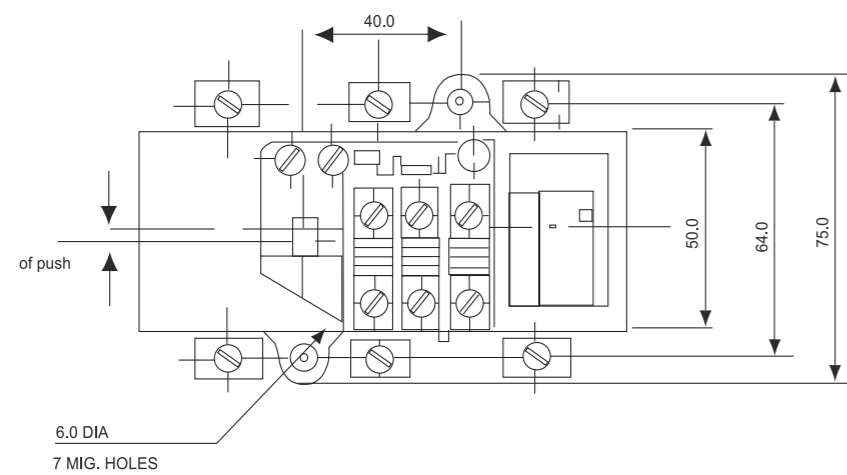

## OVERLOAD CHARACTERISTIC (Time/Current)

### CITATION DIRECT OPERATED OVERLOAD RELAY

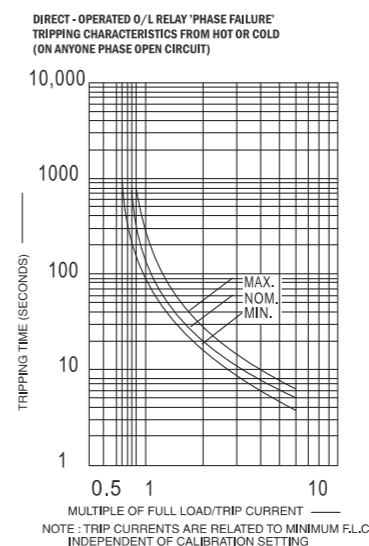
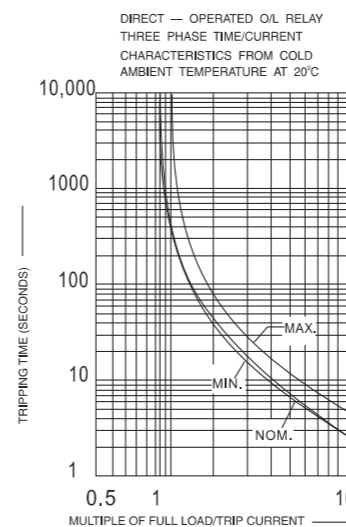

### SIZE CT\* 305ANA 3C

#### FLC CURRENT RANGES 24.44 TO 600A

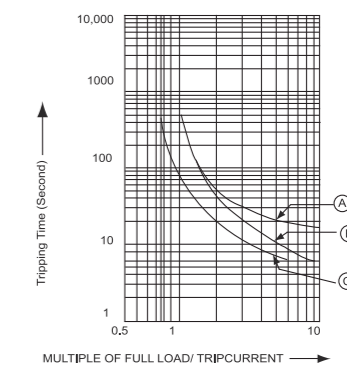

- A. Three phase characteristic at higher setting
- B. Three phase characteristic at lower setting.
- C. Single phase characteristic (Based on lower setting)

## INDUSTRIES & APPLICATIONS

BCH Contactors have proven and time tested installed base in various industries, spanning over more than four decades, of which BCH Contactors have championed in following industries against all our competition.

### Cement Plants

Cement Industries generally have very dusty environment with high ambient temperatures. This poses challenges to the switchgears. To meet these challenges we need rugged & reliable switchgear solutions

### Steel

Steel manufacturing is an extremely challenging industry which always demands rugged solutions with a focus on reducing the energy consumption

### Cranes

The challenges of Material Handling Equipment (MHE) Industries lies in providing efficient solutions related to the movement, storage, control and protection of the material. Starting, Plugging & Inching operations demands rugged switchgears

### Railways

Railways demands switching solution for the tough environmental conditions i.e. varied Temperatures, Humidity, Dusty conditions, High Vibration applications & High frequency Resistive braking.



- Coal Handling
- Ash Handling
- Kiln application
- Crane application
- Packaging plant

- Coke oven
- Hot Rolling Mill
- Blast Furnace
- Cranes
- Pulverizers

- EOT Crane
- Rotary overhead cranes
- Gantry Cranes

- Air Conditioning
- Battery chargers
- Braking

## BCH ELECTRIC LIMITED

an ISO 9001:2008 company, is today one of the leading manufacturers of low voltage electrical and electronic controls. It is a wholly owned Indian Company with a wide network of global business connections.

The company's strong focus on customer satisfaction is reflected in its wide product range, catering to the requirements of customers in the electrical field. This includes Automation, Switchgear, Enclosures, Brakes and Crane Control Products.

A strong R & D base, state-of-the-art tool design, development and manufacturing capabilities and emphasis on quality has helped the company achieve benchmarks for its products and services.

BCH Electric, as always, remains committed to customer satisfaction and loyalty, and will continue to broaden its portfolio with more services and products to further strengthen its partnership with customers.

